

ARGCO[®]
QUALITY SINCE 1981

**GROOVED
PIPING SYSTEM**

001
UL
ARGCO
FM
168.3MM
UL
6"



FIRE PROTECTION PIPING SOLUTIONS

DESIGN FEATURES



RIGID or FLEXIBLE?

ARGCO grooved couplings are classified into two types, flexible and rigid.

The following information is intended for system designers and installers to better understand the nature of the grooved piping systems. This will allow the designer and installer to make better use of the design features and advantages of grooved piping components and systems

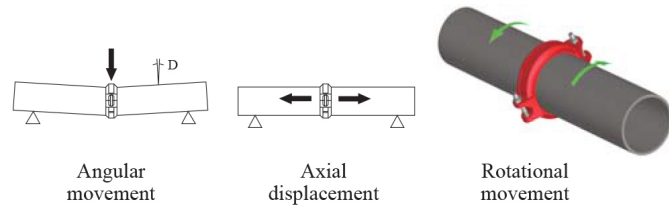

ANGLE-PAD DESIGN

Angle-pad design: As the bolts are tightened, the angled bolt pads slide in opposite directions causing the couplings keys to tightly grip the pipe, while at the same time the pipe grooves are forced outward against the coupling keys.



T&G design: The T&G (tongue & groove) mechanism provides a mechanical and frictional interlock resulting in a rigid joint which reduces undesired angular movement. ARGCO precision casting techniques allow the coupling segments to meet metal-to-metal when installed on properly grooved pipe.

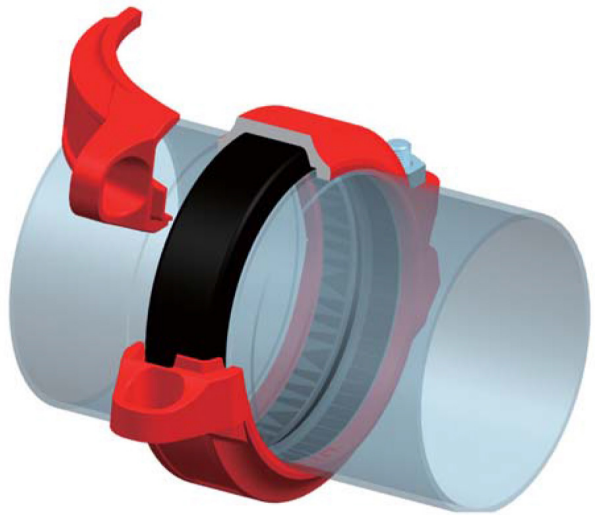

TYPE	ANGULAR MOVEMENT DEG.	AXIAL DISPLACEMENT	ROTATION AFTER INSTALLATION	MODEL NO'S
Flexible Coupling	$\geq 1^\circ$	1.6 - 3.2	Yes	104
Rigid Coupling	$< 1^\circ$	< 1.6	No	101

Note: Angular movement of flexible coupling 8" and larger sizes should be 0.5° . Axial displacement data based on roll-grooved pipe.

RIGID COUPLINGS

ARGCO rigid couplings can be used in application where you require a rigid joint similar to that of a traditional flanged, welded and or threaded connection. You need not worry about the snaking of the pipe on straight runs, as all ARGCO rigid couplings utilize both a mechanical and frictional interlock design to provide rigidity. Rigid couplings eliminate or reduce undesired angular movement, axial displacement and rotation after installation as is required under normal service conditions. Rigid couplings are some of the most popular and most widely used today.

FLEXIBLE COUPLINGS

ARGCO flexible couplings allow for full design features in applications such as curved or deflected layouts and or when systems are exposed to outside forces beyond normal static conditions such as seismic events or where vibration and or noise attenuation are a concern. The ability to design in controlled flexibility is an advantageous feature when compared to traditional rigid joining methods such as threading, flanging and welding. When designing with flexible couplings you must allow for proper support to the system so as to eliminate undesired stress. There are several published standards and codes covering grooved piping component. These codes or standards may vary as to the definition or standard for flexible couplings. System designers should confirm which standard(s) and or code(s) are required for the system being designed and they should select the applicable coupling for the application.

DESIGN FEATURES



NFPA 13 defines a FLEXIBLE COUPLING as; "a listed coupling or fitting that allows axial displacement, rotation, and at least 1 degree of angular movement of the pipe without inducing harm on the pipe. For pipe diameters of 8 in. and larger, the angular movement shall be permitted to be less than 1 degree but not less than 0.5 degrees." (NFPA 13-2007 3.5.4)

Designers and installers should design their fire protection systems in compliance with this standard.

For sprinkler systems, NFPA 13 specifies the use of flexible couplings to protect the system against damage from earthquakes and sets some specific examples of how and where they should be used.



Flexible Coupling

Axial Displacement & Angular Movement

Size		Axial Displacement in/mm	Angular Movement (Deflection)	
Nom. Size In/mm	Actual O.D. In/mm		Per Coupling Degrees	Per Pipe in/ft, mm/m
3/4" 20 mm	1.050 26.71"	0.0625 1.6	6° - 46'	1.42 118
1" 25 mm	1.315" 33.4 mm	0.0625 1.6	5° - 30'	1.16 96
1-1/4" 32 mm	1.669" 42.4 mm	0.0625 1.6	4° - 20'	0.91 76
1-1/2" 32 mm	1.9" 48.3 mm	0.0625 1.6	3° - 48'	0.80 66
2" 50 mm	2.375" 60.3 mm	0.0625 1.6	3° - 01'	0.63 53
2-1/2" 65 mm	2.875" 73 mm	0.0625 1.6	2° - 30'	0.52 44
3" 80 mm	3.5" 88.9 mm	0.0625 1.6	2° - 04'	0.43 36
4" 100 mm	4.5" 108.0 mm	0.125 3.2	3° - 24'	0.71 59.0
5" 125 mm	5.563" 141.3 mm	0.125 3.2	2° - 36'	0.54 45
6" 150 mm	6.625" 168.3mm	0.125 3.2	2° - 10'	0.45 38
8" 200 mm	8.625" 219.1 mm	0.125 3.2	1° - 40'	0.35 29
10" 250 mm	10.75" 273.0 mm	0.125 3.2	1° - 20'	0.28 23
12" 300 mm	12.75" 323.9 mm	0.125 3.2	1° - 08'	0.24 20

NOTE: Axial displacement is the maximum value when the system is pressurized to the maximum working pressure. Angular movement is the maximum value that a coupling allows under no internal pressure.

DESIGN FEATURES



MATERIALS HOUSING

The housing segments not only provide significant strength to the joint but they also compress and protect the gasket from exposure, ARGCO coupling housings and components are cast in a variety of materials as shown below.



Ductile Iron: Standard coupling housings and fittings are made of ductile iron conforming to ASTM A536 Gr. 65-45-12. The properties of Grade 65-45-12 ductile iron are as follows; 65,000 psi (448 MPa) tensile strength, 45,000 psi (310 MPa) yield strength and 12% elongation. As an option we also offer ductile iron made to ASTM A395 Gr. 60-40-18, for applications where required or where boiler codes may apply.



Stainless Steel: ARGCO offers a variety of stainless steel casting materials depending on your intended application. Standard coupling housing and fitting materials include CF8 (304), CF8M (316) or CF3M (316L) per ASTM A743. Optional materials include 2205 Duplex, 2507 Super Duplex and ASTM CK-3MCuN (UNSJ93245), equivalent to 254SMO*. (* 254SMO is a registered trademark of Avesta Polarit AQB.) Most of these materials are special order. Call your sales rep for details.



GASKETS

ARGCO gaskets are available in a variety of configurations and compounds to meet your specific requirements. These gaskets have excellent self sealing capabilities and are designed to provide a leak tight seal. During assembly the gasket is first stretched over the pipe ends which forms the initial seal. As the housing segments are installed and secured the pressure responsive gasket is slightly compressed to form a leak-tight joint. The strength of the seal is further enhanced by internal line pressure that creates downward pressure on the lips of the gasket. The gasket also seals well under vacuum conditions up to 10 inHg (254 mmHg) which may occur when a system is drained. Please refer to the ARGCO Gasket Selection Guide for additional details and gasket materials.



NUTS & BOLTS

ARGCO products utilize oval neck track bolts and heavy duty hex nuts, available either in UNC threaded or ISO metric threaded. The oval neck track bolts mate into the oval holes in the housing segments to allow for easy tightening using only a single wrench/spanner. The UNC bolts and nuts are electro zinc plated in a silver chromate color and ISO bolts and nuts in a gold chromate color.

Hot-dip galvanized bolts and nuts are also available upon request. (M10 to M22 only)

Stainless steel track bolts and nuts, type 304 or 316, are supplied with ARGCO stainless steel couplings. Stainless steel track bolts and nuts are molybdenum disulfide (MoS₂) coated to inhibit galling.

DESIGN FEATURES



Nominal Size mm/in	Pipe O.D. mm/in	Max.Working Pressure Bar/PSI	Max.End Load kN/Lbs	Axial Displacement mm/in	Angular Movement		Dimensions			Bolt Size in	Bolt Torque N-m/Lbs-Ft
					Degree Per Coupling(°)	Pipe mm/m in/ft	A mm/in	B mm/in	C mm/in		
1	2	3	4	5	6		7			8	9

DATA CHART NOTES

Nominal Size: ARGCO couplings and fittings are identified by the nominal IPS pipe size in inches or nominal diameter of pipe (DN) in millimeters.

Pipe OD: Actual outside diameter of pipe in inches and millimeters.

Maximum Working Pressure: Maximum working pressures listed are CWP (cold water pressure) or maximum allowed working pressure within the service temperature range of the gasket used in the coupling, based on standard wall or sch. 7/10/40 steel pipe, cut or roll-grooved to ANSI/AWWA C606-04 specifications. These ranges may occasionally differ from maximum working pressures listed and/or approved by UL, ULC, and/or FM as testing conditions and test pipes differ. For performance data on other pipe schedules contact ARGCO.

Note: For one time field test only the maximum joint working pressure may be increased 1.5 times the figures shown

Maximum End Load: Maximum end loads listed are total of internal and external forces to which the joint can be subjected, based on standard wall or sch. 7/10/40 steel pipe, cut or roll-grooved to ANSI/AWWA C606-04 specifications.

Axial Displacement: Designed range of the gap between pipe ends based on roll grooved pipe.

Angular Movement (Deflection): Maximum allowable deflection of pipe from centerline when the joint is used with cut or roll-grooved steel pipe under no internal pressure.

Dimensions: "A," "B," "C" and so on are external dimensions for reference purpose only in millimeters and inches

Bolt Size: UNC bolt size and length in inches and ISO metric bolt size and length in millimeters with numbers of bolts where applicable.

Bolt Torque: Recommended bolt fastening torque in Lbs-Ft and N-m.

GENERAL NOTES

Service Fluid and Temperature: Service fluid and temperature limitations for ARGCO couplings are primarily governed by the gasket used within the coupling. Always refer to and consult the ARGCO Gasket Selection Guide.

Working Pressure: ARGCO grooved couplings are generally engineered for use with standard or sch. 7/10/40 steel pipes (except for some high pressure models) and can be used within the rated working pressures as shown in the ARGCO literature. A one me only field test at 1.5 times the working pressure is allowed.

As there are limitations in service temperatures, the ARGCO couplings and fittings do not adopt the ANSI temperature- pressure ranges (Class 150, Class 300, etc.), ISO or JIS methods of pressure ranges (PN10, PN16, JIS 10K or 20K, etc.). All the published working pressures are CWP, non-shock cold water pressures, unless otherwise specified. Actual allowed working pressures for a specific coupling will vary depending on the coupling size, pipe material, pipe schedule (or thickness) and types of grooves used. Special attention is required when using thin wall stainless steel pipe such as sch. 5. For further details request the performance data for specific thin wall pipe.

The dimensions, weights, performance data, and other specifications shown in this catalog supersede all previous published data.

ARGCO reserves the right to change product designs and or specifications without notice and without obligation.

Illustrations shown within this catalog are for illustrative purposes. They are not drawn to scale and may have been exaggerated for clarity. Any person who makes use of the information or materials contained herein shall do so at their own risk and shall be liable for any results arising from such use.

GROOVED COUPLINGS - STANDARD RIGID

Model 101



The ARGCO Model 101 is an angle-pad design standard rigid coupling for moderate pressure piping services including fire mains, long straight runs and value connections.

The angle-pad design allows the coupling housings to slide along the bolt pads when tightened. The result is an offset clamping action which provides a rigid joint which resists so-called 'snaking' of a long straight run. Support and hanging requirements correspond to ANSI B31.1, B31.9 and NFPA 13. With the removal of only one bolt you can make a fast and easy 'swing-over' installation.

Available Sizes

- 1" through 12" (25 through 300 mm)

Pipe Material

- Carbon steel, Schedule 10, Schedule 40.

For use with alternative materials and wall thicknesses please contact ARGCO.

Maximum Working Pressure

- Up to 300 psi/2517 kPa.

Function

- Joins carbon steel pipe.
- Provides a rigid pipe joint designed to restrict axial or angular movement.

CERTIFICATIONS/LISTINGS

Underwriters Laboratories, Underwriters Laboratories Canada, Factory Mutual.

SPECIFICATIONS - MATERIAL

Housing Sections: Ductile Iron conforming to ASTM A 536, Grade 65-45-12.

Housing Coating:

Standard: Orange Enamel

Available: Hot Dipped Galvanized

Gasket:

Standard: Grade E EPDM (Type A)

ARGCO's products are listed by Underwriters Laboratories UL Canada and Approved by Factory Mutual for wet and dry (oil free air) sprinkler services within the rated working pressure.

Bolts and Nuts

Standard: Carbon Steel oval neck track bolts meeting ASTM A449 and ISO 898-1. Carbon steel hex nuts meet ASTM A563 Grade B.

Nuts and Bolts are zinc electroplated per ASTM B633 NZ/FE5, finish Type III.

Available: Stainless Steel. Meets ASTM F593, Group 2 (316 stainless steel), condition CW.

Hex nuts meet ASTM F594, Group 2 (316 stainless steel), condition CW, with galling-resistant coating.

GROOVED COUPLINGS - STANDARD RIGID

Model 101

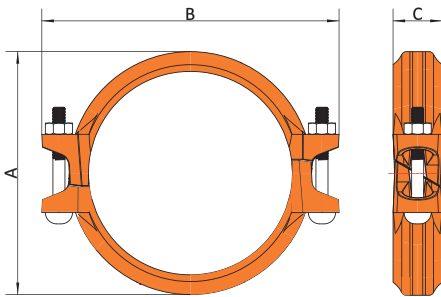

ARGCO Grooved Couplings are suitable for fire protection systems, water supply systems, and other process systems of higher working pressure.

Item #	Nominal Size in/mm	Maximum Working Pressure psi/kPa	Maximum End Load lb/N	Axial Displacement in/mm	Dimensions			Bolt inches mm	Weight lb
					A inches mm	B inches mm	C inches mm		
7010001	1"	300	405	0-0.06	2.17	3.82	1.77	3/8" x1-1/2"	0.81
	25	20	1.80	0-1.6	55	97	45	M10x40	
7010002	1-1/4"	300	656	0-0.06	2.50	4.23	1.77	3/8" x1-3/4"	1.23
	32	20	2.92	0-1.6	63.5	107.5	45	M10x45	
7010003	1-1/2"	300	852	0-0.06	2.72	4.49	1.77	3/8" x1-3/4"	1.32
	40	20	3.79	0-1.6	69	114	45	M10x45	
7010004	2"	300	1327	0-0.06	3.29	4.88	1.81	3/8" x 2-1/8"	1.58
	50	20	5.91	0-1.6	83.6	124	46	M10x55	
7010005	2-1/2"	300	1945	0-0.06	3.86	5.39	1.81	3/8" x 2-1/8"	2.13
	65	20	8.66	0-1.6	98	137	46	M10x55	
7010006	3"	300	2885	0-0.06	4.49	6.14	1.81	3/8" x 2-1/8"	2.70
	80	20	12.84	0-1.6	114	156	46	M10x55	
7010007	4"	300	4258	0-0.16	5.43	7.32	1.97	1/2" x 2-5/8"	2.94
	100	20	18.94	0-4.1	138	186	50	M12x65	
7010008	5"	300	6457	0-0.16	6.46	8.39	1.97	1/2" x 2-5/8"	4.70
	125	20	28.73	0-4.1	164	213	50	M12x65	
7010009	6"	300	9229	0-0.06	7.56	9.61	1.97	1/2" x 2-5/5"	5.50
	150	20	41.06	0-4.1	192	244	50	M12x65	
7010010	8"	300	17079	0-0.16	10.00	13.39	2.44	5/8" x3-1/2 "	11.73
	200	20	75.99	0-4.1	254	340	62	M16x90	
7010011	10"	300	26101	0-0.16	12.32	15.75	2.52	3/4" x3-1/2"	18.08
	250	20	116.13	0-4.1	313	400	64	M20x90	
7010012	12"	300	37031	0-0.16	14.49	18.27	2.52	7/8" x4-1/3"	22.4
	300	20	164.76	0-4.1	368	464	64	M22x110	

- Working Pressure and End Load are total, from all internal and external loads, based on standard weight (ANSI) steel pipe, standard roll or cut grooved in accordance with ARGCO specifications.
- The allowable pipe separation dimension shown is for system layout purposes only. ARGCO couplings are considered rigid connections and will not accommodate expansion or contraction of the piping system.
- When assembling ARGCO couplings onto end caps, take additional care to make certain the end cap is fully seated against the gasket end stop.

GROOVED COUPLINGS - STANDARD RIGID

Model 101



INSTALLATION INSTRUCTIONS:

STANDARD RIGID COUPLING

Depressurize and drain the piping system before attempting to install, remove, or adjust any piping products.

Wear safety glasses, hard hat, and foot protection.

1. CHECK PIPE ENDS:

The outside surface of the pipe from the pipe end to the groove must be smooth and free from indentations, projections (including weld seams), and roll marks to ensure a leaktight seal for the gasket. All oil, grease, loose paint, and dirt must be removed.

2. CHECK GASKET AND LUBRICATE :

Check the gasket to make sure it is suitable for the intended service. Apply a thin coat of Tuf-Lube Gasket Grease Lubricant to the gasket lips and exterior.

3. POSITION GASKET:

Position the gasket over the pipe end. Make sure the gasket does not overhang the pipe end.

4. JOIN PIPE ENDS:

Align and bring the two pipe ends together. Slide the gasket into position, and make sure it is centered between the grooves in each pipe.

Make sure no portion of the gasket extends into the groove in either pipe.

5. ASSEMBLE HOUSINGS:

Insert one bolt into the housings, and thread the nut loosely onto the bolt (nut should be flush with end of bolt) .

6. INSTALL HOUSINGS:

Install the housings over the gasket. Make sure the housings' keys engage the grooves properly on both pipes.

Torque Value

When a torque value is specified for coupling installation, this torque **MUST** be applied to the nuts in order to achieve proper installation. However, torque beyond specified values will not improve sealing.

Exceeding the specified torque by more than 25% may cause damage to the product, resulting in pipe-joint failure.

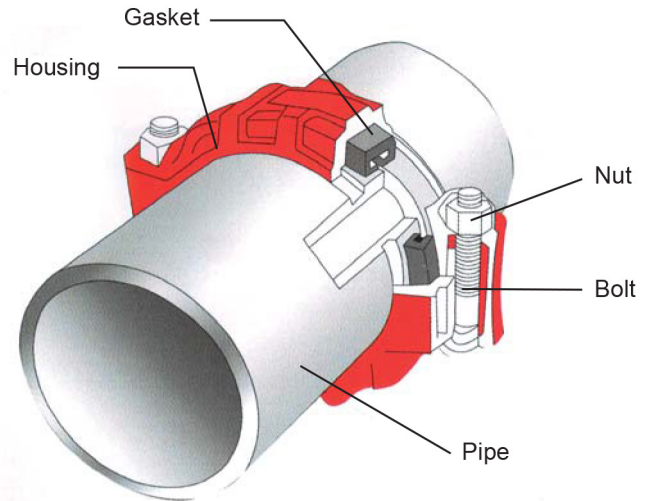

SPECIFIED TORQUE (LB/FT.)

SIZE	MIN	MAX
1"	30	45
1-1/4"	30	45
1-1/2"	30	45
2"	80	100
2-1/2"	80	100
3"	80	100
3-1/2"	100	130
4"	100	130

Using Impact Wrenches

When using an impact wrench, the speed of assembly may require extra care to ensure nuts are tightened evenly by alternating sides until proper assembly is complete.

Impact wrenches do not provide the installer with direct "wrench feel" or torque to judge nut tightness. Since some impact wrenches are capable of high output, it is important to develop a familiarity with the impact wrench to avoid damaging or fracturing bolts or coupling bolt pads during installation.

DO NOT continue to use an impact wrench after the visual installation guidelines for the coupling are achieved.

Perform trial assemblies with the impact wrench and socket or torque wrenches to help determine the capability of the impact wrench. Using the same method, periodically check additional nuts throughout the system installation.

In addition, verify that proper impact grade sockets are being used for coupling installation.

GROOVED COUPLINGS - STANDARD FLEXIBLE

Model 104

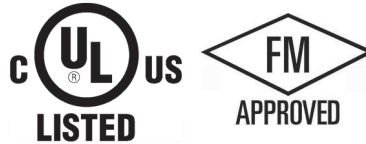

Available Sizes

- 1" through 12" (25 through 300 mm)

Pipe Material

- Carbon steel, Schedule 10, Schedule 40.
For use with alternative materials and wall thicknesses please contact ARGCO.

Maximum Working Pressure

- Up to 300 psi/2517 kPa.

Function

- Joins carbon steel pipe.
- Provides a rigid pipe joint designed to restrict axial or angular movement.

CERTIFICATIONS/LISTINGS

Underwriters Laboratories, Underwriters Laboratories Canada, Factory Mutual.

SPECIFICATIONS - MATERIAL

Housing Sections: Ductile Iron conforming to ASTM A 536, Grade 65-45-12.

Housing Coating:

Standard: Orange Enamel

Available: Hot Dipped Galvanized

Gasket:

Standard: Grade E EPDM (Type A)

ARGCO's products are listed by Underwriters Laboratories UL Canada and Approved by Factory Mutual for wet and dry (oil free air) sprinkler services within the rated working pressure.

Bolts and Nuts

Standard: Carbon Steel oval neck track bolts meeting ASTM A449 and ISO 898-1. Carbon steel hex nuts meet ASTM A563 Grade B.

Nuts and Bolts are zinc electroplated per ASTM B633 NZ/FE5, finish Type III.

Available: Stainless Steel. Meets ASTM F593, Group 2 (316 stainless steel), condition CW.

Hex nuts meets ASTM F594, Group 2 (316 stainless steel), condition CW, with galling-resistant coating.

GROOVED COUPLINGS - STANDARD FLEXIBLE

Model 104

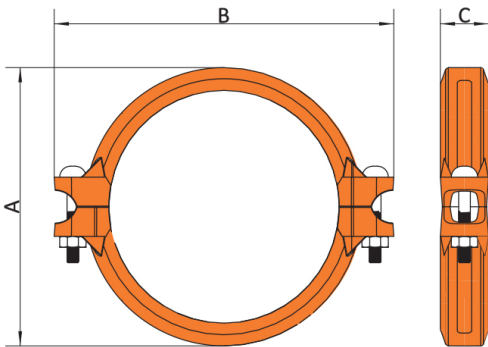

ARGCO Grooved Couplings are suitable for fire protection systems, water supply systems, and other process systems of higher working pressure.

Item #	Nominal Size in/mm	Maximum Working Pressure psi/kPa	Maximum End Load lb/N	Axial Displacement in/mm	Angular Movement		Dimensions			Bolt inches mm
					per coupling degrees	per pipe in/ft, mm/m	A inches mm	B inches mm	C inches mm	
7010015	1"	300	405	0.0625	5° - 30'	0.71	2.17	3.82	1.77	3/8" x1-1/2"
	25	20	1.80	1.6			58	55	97	45
7010016	1-1/4"	300	656	0.0625	4° - 20'	0.58	2.50	4.23	1.77	3/8" x1-3/4"
	32	20	2.92	1.6			48	63.5	107.5	45
7010017	1-1/2"	300	852	0.0625	3° - 48'	0.45	2.72	4.49	1.77	3/8" x1-3/4"
	40	20	3.79	1.6			38	69	114	45
7010018	2"	300	1327	0.0625	3° - 01'	0.4	3.29	4.88	1.81	3/8" x 2-1/8"
	50	20	5.91	1.6			33	83.6	124	46
7010019	2-1/2"	300	1945	0.0625	2° - 30'	0.31	3.86	5.39	1.81	3/8" x 2-1/8"
	65	20	8.66	1.6			26	98	137	46
7010020	3"	300	2885	0.0625	2° - 04'	0.21	4.49	6.14	1.81	3/8" x 2-1/8"
	80	20	12.84	1.6			18	114	156	46
7010021	4"	300	4258	0.125	3° - 14'	0.34	5.43	7.32	1.97	1/2" x 2-5/8"
	100	20	18.94	3.2			28	138	186	50
7010022	5"	300	6457	0.125	2° - 53'	0.27	6.46	8.39	1.97	1/2" x 2-5/8"
	125	20	28.73	3.2			23	164	213	50
7010023	6"	300	9229	0.125	2° - 18'	0.23	7.56	9.61	1.97	1/2" x 2-5/8"
	150	20	41.06	3.2			19	192	244	50
7010024	8"	300	17079	0.125	1° - 40'	0.18	10.00	13.39	2.44	3/4" x 3-1/2"
	200	20	75.99	3.2			15	254	340	62
7010025	10"	300	26101	0.125	1° - 20'	0.14	12.32	15.75	2.52	3/4" x3-1/2"
	250	20	116.13	3.2			12	313	400	64
7010026	12"	300	37031	0.125	1° - 08'	0.12	14.49	18.27	2.52	7/8" x4-1/3"
	300	20	164.76	3.2			10	368	464	64

Note: Allowable Axial Displacement figures are for roll grooved standard steel pipe. Values for cut grooved pipe will be double that of roll grooved. These values are maximums; for design and installation purposes these figures should be reduced by: 50% for 3/4" - 3 1/2"; 25% for 4" and larger to compensate for jobsite conditions.

- Working Pressure and End Load are total, from all internal and external loads, based on standard weight (ANSI) steel pipe, standard roll or cut grooved in accordance with ARGCO specifications.
- When assembling ARGCO couplings onto end caps, take additional care to make certain the end cap is fully seated against the gasket end stop.

The NFPA 13 defines a flexible coupling as;

"a listed coupling or fitting that allows axial displacement, rotation, and at least 1 degree of angular movement of the pipe without inducing harm on the pipe. For pipe diameters of 8 in. and larger, the angular movement shall be permitted to be less than 1 degree but not less than 0.5 degrees." (NFPA 13- 2007 3.5.4)

For sprinkler systems, NFPA 13 specifies the use of flexible couplings to protect the system against damage from earthquakes and sets some specific examples of how and where they should be used. Designers and installers should design their fire protection systems in compliance with this standard.

GROOVED REDUCING COUPLINGS

Model 105

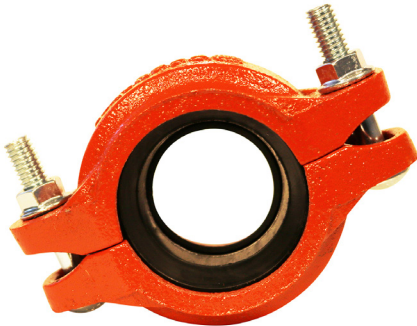

The ARGCO Model 105 reducing coupling allows for direct reduction on a piping run and eliminates the need for a concentric reducer and couplings. The specially designed rubber gasket helps prevent small pipe from telescoping into larger pipe during vertical assembly.

Caution: Model 105 couplings should not be used with an end cap, as the end may be sucked into the pipe when draining the system.

Pipe Material

- Carbon steel, Schedule 10, Schedule 40.

For use with alternative materials and wall thicknesses please contact ARGCO.

Maximum Working Pressure

- Up to 300 psi/2517 kPa.

Function

- Joins carbon steel pipe.
- Provides a rigid pipe joint designed to restrict axial or angular movement.

CERTIFICATIONS/LISTINGS

Underwriters Laboratories, Underwriters Laboratories Canada, Factory Mutual.

SPECIFICATIONS - MATERIAL

Housing Sections: Ductile Iron conforming to ASTM A 536, Grade 65-45-12.

Housing Coating:

Standard: Orange Enamel

Available: Hot Dipped Galvanized

Gasket:

Standard: Grade E EPDM (Type A)

ARGCO's products are listed by Underwriters Laboratories UL Canada and Approved by Factory Mutual for we and dry (oil free air) sprinkler services within the rated working pressure.

Bolts and Nuts

Standard: Carbon Steel oval neck track bolts meeting ASTM A449 and ISO 898-1. Carbon steel hex nuts meet ASTM A563 Grade B.

Nuts and Bolts are zinc electroplated per ASTM B633 NZ/FE5, finish Type III.

Available: Stainless Steel. Meets ASTM F593, Group 2 (316 stainless steel), condition CW.

Hex nuts meets ASTM F594, Group 2 (316 stainless steel), condition CW, with galling-resistant coating.

GROOVED REDUCING COUPLINGS

Model 105

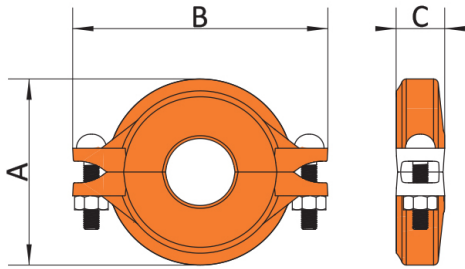

ARGCO Grooved Couplings are suitable for fire protection systems, water supply systems, and other process systems of higher working pressure.

Item #	Nominal Size in/mm	Actual O.D. in/mm	Max. Working Pressure psi/Bar	Max. End Load Lbs/KN	Axial Displacement in/mm	Deflection		Dimensions			Bolt Size inches mm
						Degree Per Coupling (°)	Pipe in/ft mm/m	A inches mm	B inches mm	C inches mm	
7010109	1-1/2 x 1-1/4	1.9 x 1.669	300	852	0.0625	1° - 54'	33	2.76	4.45	1.77	3/8 x 2
	40 x 32	48.3 x 42.4	20	3.79	1.6	1° - 54'	0.4	70	113	45	M10 x 50
7010110	2 x 1-1/4	2.375 x 1.669	300		0.0625						3/8 x 2
	50 x 32	60.3 x 42.4	20		1.6						M10 x 50
7010111	2 x 1-1/2	2.375 x 1.9	300	1327	0.0625	1° - 31'	27	3.23	5.12	1.81	3/8 x 2-1/8
	50 x 40	60.3 x 48.3	20	5.91	1.6	1° - 31'	0.32	82	130	46	M10 x 50
7010112	2-1/2 x 2	2.875 x 2.375	300	1945	0.0625	1° - 15'	22	3.82	5.94	1.81	3/8 x 2-1/8
	65 x 50	73 x 60.3	20	8.66	1.6	1° - 15'	0.26	97	151	46	M10 x 50
7010113	3 x 2	3.5 x 2.375	300	2885	0.0625	1° - 02'	18	4.41	6.56	1.81	1/2 x 2-5/8
	80 x 50	88.9 x 60.3	20	12.84	1.6	1° - 02'	0.22	112	166.6	46	M12 x 65
7010114	3 x 2-1/2	3.5 x 2.875	300	2885	0.0625	1° - 02'	18	4.41	6.56	1.81	1/2 x 2-5/8
	80 x 65	88.9 x 73.0	20	12.84	1.6	1° - 02'	0.22	112	166.6	46	M12 x 65
7010115	4 x 2	4.5 x 2.375	300	4769	0.125	1° - 36'	28	5.55	7.87	1.97	1/2 x 2-5/8
	100 x 50	114.3 x 2.375	20	21.22	3.2	1° - 36'	0.34	141	200	50	M12 x 65
7010116	4 x 2-1/2	4.5 x 2.875	300	4769	0.125	1° - 36'	28	5.55	7.87	1.97	1/2 x 2-5/8
	100 x 65	114.3 x 73.0	20	21.22	3.2	1° - 36'	0.34	141	200	50	M12 x 65
7010117	4 x 3	4.5 x 3.5	300	4769	0.125	1° - 36'	28	5.58	7.87	1.97	1/2 x 2-5/8
	100 x 80	114.3 x 88.9	20	21.22	3.2	1° - 36'	0.34	141.8	200	50	M12 x 65
7010118	5 x 4	5.56 x 4.5	300	7124	0.125	1° - 18'	23	6.65	9.25	2.05	5/8 x 3-1/8
	125 x 100	139.7 x 114.3	20	31.70	3.2	1° - 18'	0.27	169	235	52	M16 x 80
7010119	6 x 4	6.625 x 4.5	300	9950	0.125	1° - 07'	20	7.76	10.83	2.05	5/8 x 3-1/8
	150 x 100	165.1 x 114.3	20	44.27	3.2	1° - 07'	0.24	197	275	52	M16 x 80
7010120	8 x 6	8.625 x 6.625	300	17524	0.125	1° - 50'	15	10.08	13.23	2.28	3/4 x 4-1/3
	200 x 150	219.1 x 168.3	20	77.97	3.2	1° - 50'	0.18	256	336	58	M20 x 110

- Deflection or angular movement is the maximum value that a coupling allows under no internal pressure.
- Working Pressure and End Load are total, from all internal and external loads, based on standard weight (ANSI) steel pipe, standard roll or cut grooved in accordance with ARGCO specifications.
- The allowable pipe separation dimension shown is for system layout purposes only. ARGCO couplings are considered rigid connections and will not accommodate expansion or contraction of the piping system.

GROOVED STANDARD RADIUS ELBOWS

Models 201, 208, 205 +, 207



Available Sizes

- 1" through 12" (25 through 300 mm)

Pipe Material

- Carbon steel, Schedule 10, Schedule 40.
For use with alternative materials and wall thicknesses please contact ARGCO.

Maximum Working Pressure

- Up to 300 psi/20 bar

Function

- Joins carbon steel pipe.
- Provides a rigid pipe joint designed to restrict axial or angular movement.

CERTIFICATIONS/LISTINGS

Underwriters Laboratories, Underwriters Laboratories Canada, Factory Mutual.

SPECIFICATIONS - MATERIAL

Housing Sections: Ductile Iron conforming to ASTM A 536, Grade 65-45-12.

Housing Coating:

Standard: Orange Enamel

Available: Hot Dipped Galvanized

GROOVED STANDARD RADIUS ELBOWS

Models 201, 208, 206, 207

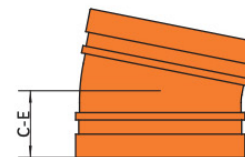
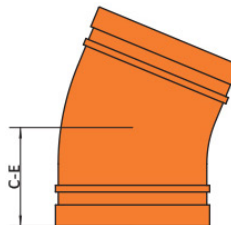
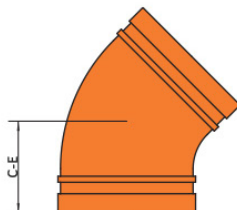
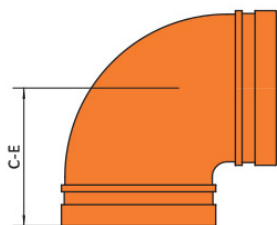

Nominal Size in/mm	Pipe O.D. in/mm	Max Working Pressure psi/Bar	Model 201 90° Elbow Standard		Model 208 45° Elbow		Model 206 22.5° Elbow		Model 207 11.25° Elbow	
			Item #	C-E inches mm	Item #	C-E inches mm	Item #	C-E inches mm	Item #	C-E inches mm
1-1/4"	1.669	300	7010041	2.76	7010062	1.77	7010073	1.77	7010245	1.38
32	42.4	20		70		45		45		35
1-1/2"	1.9	300	7010042	2.76	7010063	1.77	7010074	1.89	7010246	1.38
40	48.3	20		70		45		48		35
2"	2.375	300	7010043	3.27	7010064	2.01	7010075	2.01	7010247	1.50
50	60.3	20		83		51		51		38
2-1/2"	2.875	300	7010044	3.74	7010065	2.44	7010076	2.01	7010248	1.50
65	73	20		95		62		51		38
3"	3.5	300	7010045	4.25	7010066	2.76	7010077	2.87	7010249	1.77
80	88.9	20		108		70		73		45
4"	4.5	300	7010046	5	7010067	2.99	7010078	2.87	7010250	1.77
100	114.3	20		127		76		73		45
5"	5.563	300	7010047	5.51	7010068	3.27	7010079	2.87	7010251	2.01
125	141.3	20		140		83		73		51
6"	6.625	300	7010048	6.25	7010069	3.50	7010080	3.11	7010252	2.01
150	168.3	20		165		89		79		51
8"	8.625	300	7010049	7.76	7010070	4.25	7010081	4.37	7010253	2.13
200	219.1	20		197		108		111		54
10"	10.75	300	7010050	9.02	7010071	4.76	7010082	4.88	7010254	2.24
250	273	20		229		121		124		57
12"	12.75	300	7010051	10	7010072	---	7010083	---	7010255	---
300	323.9	20		254		---		---		---

- Working Pressure and End Load are total, from all internal and external loads, based on standard weight (ANSI) steel pipe, standard roll or cut grooved in accordance with ARGCO specifications.
- The allowable pipe separation dimension shown is for system layout purposes only. ARGCO couplings are considered rigid connections and will not accommodate expansion or contraction of the piping system.
- When assembling ARGCO couplings onto end caps, take additional care to make certain the end cap is fully seated against the gasket end stop.

GROOVED END OF RUN REDUCING ELBOW (ADACAP) MODEL 203A



Ductile iron 90° grooved-end elbow with base support, designed for installation at the bottom of a riser system. An anchor can be placed in conjunction with the base to support the weight of the pipe, coupling and fluid.

Pipe Material

- Carbon steel, Schedule 10, Schedule 40.

Maximum Working Pressure

- Up to 300 psi/20 bar

Function

- Joins carbon steel pipe grooved pipe to threaded.

CERTIFICATIONS/LISTINGS

Underwriters Laboratories,
Underwriters Laboratories Canada, Factory Mutual.

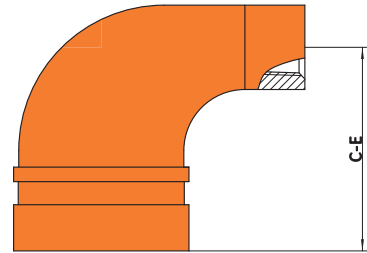

SPECIFICATIONS - MATERIAL

Housing Sections:

Ductile Iron conforming to
ASTM A 536, Grade 65-45-12.

Housing Coating:

Standard: Orange Enamel
Available: Hot Dipped
Galvanized

Item #	Nominal Size in/mm	NPT BSP	Max Working Pressure psi/Bar	C-E inches mm
7010260	1-1/4" x 1/2"	1/2"	300	2.40
	32 x 15	15	20	61
7010261	1-1/4" x 3/4"	3/4"	300	2.40
	32 x 20	20	20	61
7010262	1-1/4" x 1"	1"	300	2.40
	32 x 25	25	20	61
7010263	1-1/2" x 1/2"	1/2"	300	2.52
	40 x 15	15	20	64
7010264	1-1/2" x 3/4"	3/4"	300	2.52
	40 x 20	20	20	64
7010265	1-1/2" x 1"	1"	300	2.52
	40 x 25	25	20	64
7010266	2" x 1/2"	1/2"	300	2.52
	50 x 15	15	20	64
7010267	2" x 3/4"	3/4"	300	2.76
	50 x 20	20	20	70
7010268	2" x 1"	1"	300	2.76
	50 x 25	25	20	70
7010268A	2-1/2" x 3/4"		300	
	65 x 20		20	
7010268B	2-1/2" x 1"		300	
	65 x 25		20	
7010268C	3" x 1"		300	
	50 x 25		20	

GROOVED SHORT RADIUS ELBOWS & TEES

Models 301, 302



ARGCO short radius fittings, while primarily designed for fire protection applications, can also be used for general service requirements



Available Sizes

- 2" through 12" (50 through 300 mm)

Pipe Material

- Carbon steel, Schedule 10, Schedule 40.
For use with alternative materials and wall thicknesses please contact ARGCO.

Maximum Working Pressure

- Up to 300 psi/20 bar

Function

- Joins carbon steel pipe.
- Provides a rigid pipe joint designed to restrict axial or angular movement.

CERTIFICATIONS/LISTINGS

Underwriters Laboratories, Underwriters Laboratories Canada, Factory Mutual.

SPECIFICATIONS - MATERIAL

Housing Sections: Ductile Iron conforming to ASTM A 536, Grade 65-45-12.

Housing Coating:

Standard: Orange Enamel

Available: Hot Dipped Galvanized

GROOVED SHORT RADIUS ELBOWS & TEES

Models 301, 302

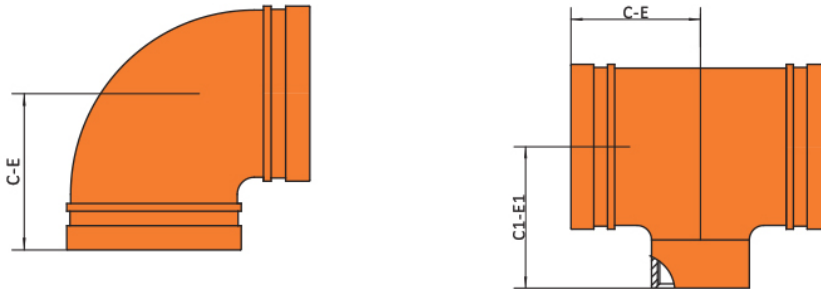

Nominal Size in/mm	Pipe O.D. in/mm	Max Working Pressure psi/Bar	Model 301 90° Elbow Short		Model 302 Tee Short	
			Item #	C-E inches mm	Item #	C-E inches mm
2"	2.375	300	7010032	2.76	7010085	2.76
50	60.3	20		70		70
2-1/2"	2.875	300	7010033	2.99	7010086	2.99
65	73	20		76		76
3"	3.5	300	7010034	3.35	7010087	3.35
80	88.9	20		85		85
4"	4.5	300	7010035	4.02	7010088	4.02
100	114.3	20		102		102
5"	5.56	300	7010036	4.76	7010089	4.76
125	141.3	20		121		121
6"	6.625	300	7010037	5.12	7010090	5.12
150	168.3	20		130		130
8"	8.625	300	7010038	6.89	7010091	6.89
200	219.1	20		130		175

- Working Pressure and End Load are total, from all internal and external loads, based on standard weight (ANSI) steel pipe, standard roll or cut grooved in accordance with ARGCO specifications.

User Responsibility for Product Selection and Suitability

Each user bears final responsibility for making a determination as to the suitability of ARGCO products for a particular end-use application, in accordance with industry standards and project specifications, and the applicable building codes and related regulations as well as ARGCO performance, maintenance, safety, and warning instructions. Nothing in this or any other document, nor any verbal recommendation, advice, or opinion from any ARGCO employee, shall be deemed to alter, vary, supersede, or waive any provision of Allied Rubber and Gasket Company's standard conditions of sale, installation guide, or this disclaimer.

Note

All products to be installed in accordance with current ARGCO installation/assembly instructions. ARGCO reserves the right to change product specifications, designs and standard equipment without notice and without incurring obligations.

Installation

Reference should always be made to the ARGCO installation instructions of the product you are installing.

Warranty

Refer to the Warranty section of the current Price List or contact ARGCO for details.

GROOVED DRAIN ELBOW

Model 2601



The Model DE1 is a grooved-end ductile iron cast elbow with an integral 1" NPT drain.
The DE1 was primarily designed for, but not limited to, used on fire protection standpipes

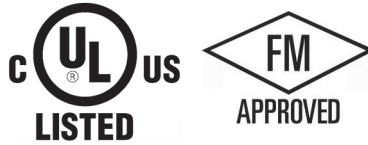

Pipe Material

- Carbon steel, Schedule 10, Schedule 40.

Maximum Working Pressure

- Up to 300 psi/20 bar

Function

- Joins carbon steel pipe.
- Provides a rigid pipe joint designed to restrict axial or angular movement.

CERTIFICATIONS/LISTINGS

Underwriters Laboratories,
Underwriters Laboratories Canada,
Factory Mutual.

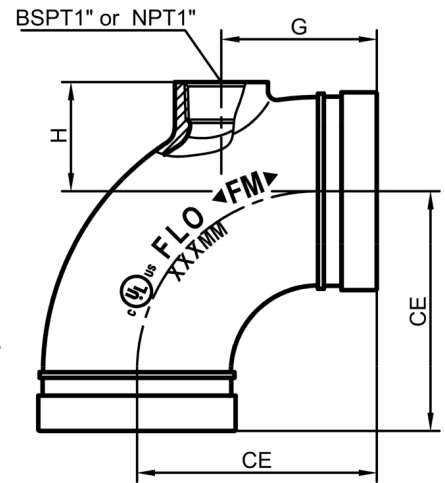

SPECIFICATIONS - MATERIAL

Housing Sections:

Ductile Iron conforming to ASTM A 536, Grade 65-45-12.

Housing Coating:

Standard: Orange Enamel
Available:
Hot Dipped Galvanized

Item #	Nominal Size in/mm	Pipe O.D. in/mm	Max Working Pressure psi/Bar	Dimensions		
				C-E inches mm	H inches mm	G inches mm
7010054	2	2.375	300	2.27	1.75	2.0
	50	60.3	20	83	44.5	50.8
7010055	2-1/2	2.875	300	3.74	2.75	2.0
	65	73.0	20	95	69.85	50.8
7010056	3	3.5	300	4.25	2.50	2.0
	80	88.9	20	108	63.5	50.8
7010057	4	4.5	300	5.00	3.0	2.25
	100	114.3	20	127	76.2	57.15
7010058	6	6.625	300	6.50	4.0	2.50
	150	1658.3	20	185	101.6	63.5

- Working Pressure is total, from all internal and external loads, based on standard weight (ANSI) steel pipe, standard roll or cut grooved in accordance with ARGCO specifications.
- The allowable pipe separation dimension shown is for system layout purposes only. ARGCO couplings are considered rigid connections and will not accommodate expansion or contraction of the piping system.
- When assembling ARGCO couplings onto end caps, take additional care to make certain the end cap is fully seated against the gasket end stop.

GROOVED STANDARD RADIUS TEES & CROSSES

Models 301, 401



Available Sizes

- 2" through 12" (50 through 300 mm)

Pipe Material

- Carbon steel, Schedule 10, Schedule 40.
For use with alternative materials and wall thicknesses please contact ARGCO.

Maximum Working Pressure

- Up to 300 psi/20 bar

Function

- Joins carbon steel pipe.
- Provides a rigid pipe joint designed to restrict axial or angular movement.

CERTIFICATIONS/LISTINGS

Underwriters Laboratories, Underwriters Laboratories Canada, Factory Mutual.

SPECIFICATIONS - MATERIAL

Housing Sections: Ductile Iron conforming to ASTM A 536, Grade 65-45-12.

Housing Coating:

Standard: Orange Enamel

Available: Hot Dipped Galvanized

GROOVED TEES & CROSSES

Models 301, 401

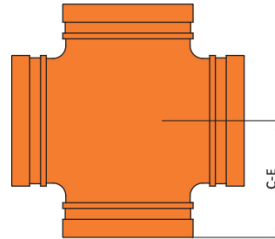
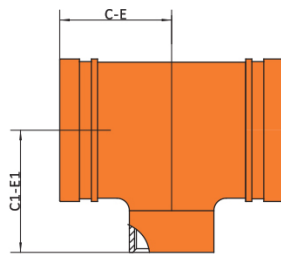

Nominal Size in/mm	Pipe O.D. in/mm	Max Working Pressure psi/Bar	Model 301 Tee		Model 401 Cross	
			Item #	C-E inches mm	Item #	C-E inches mm
1"	1.327	300	7010092A			
25	33.4	20				
1-1/4"	1.669	300	7010092	2.76	7010230	
32	42.4	20		70		
1-1/2"	1.9	300	7010093	2.76	7010231	
40	48.3	20		70		
2"	2.375	300	7010094	3.31	7010232	7.00
50	60.3	20		84		178
2-1/2"	2.875	300	7010095	3.74	7010233	7.75
65	73	20		95		197
3"	3.5	300	7010096	4.25	7010234	8.50
80	88.9	20		108		216
4"	4.5	300	7010097	5.00	7010235	10.50
100	114.3	20		127		12.50
5"	5.56	300	7010098	5.51	7010236	318
125	141.3	20		140		14.00
6"	6.625	300	7010099	6.50	7010237	356
150	168.3	20		165		18.00
8"	8.625	300	7010100	7.76	7010238	457
200	219.1	20		197		20.50
10"	10.75	300	7010101	9.02	7010239	521
250	273	20		229		23.00
12"	12.75	300	7010102	10.00	7010240	584
300	323.9	20		254		

- Working Pressure and End Load are total, from all internal and external loads, based on standard weight (ANSI) steel pipe, standard roll or cut grooved in accordance with ARGCO specifications.

GROOVED REDUCING TEES

Model 303

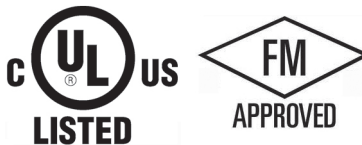

Pipe Material

- Carbon steel, Schedule 10, Schedule 40.
For use with alternative materials and wall thicknesses please contact ARGCO.

Maximum Working Pressure

- Up to 300 psi/20 bar

Function

- Joins carbon steel pipe.
- Provides a rigid pipe joint designed to restrict axial or angular movement.

CERTIFICATIONS/LISTINGS

Underwriters Laboratories, Underwriters Laboratories Canada, Factory Mutual.

SPECIFICATIONS - MATERIAL

Housing Sections: Ductile Iron conforming to ASTM A 536, Grade 65-45-12.

Housing Coating:

Standard: Orange Enamel

Available: Hot Dipped Galvanized

GROOVED REDUCING TEES

Model 303

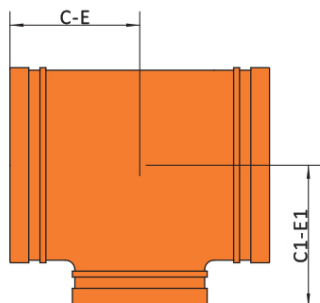

Item #	Nominal Size in/mm	Pipe O.D. in/mm	Max Working Pressure psi/Bar	Dimensions	
				C1-E1 inches mm	C-E inches mm
7010500	2 x 1-1/4	2.375 X 1.669	300	2.76	2.76
	50 x 32	60.3 x 42.4	20	70	70
7010501	2 x 1-1/2	2.375 x 1.9	300	2.76	2.76
	50 x 40	60.3 x 48.3	20	70	70
7010502	2-1/2 x 1-1/4	2.875 x 1.669	300	2.99	2.99
	65 x 32	73 x 42.4	20	76	76
7010503	2-1/2 x 1-1/2	2.875 x 1.9	300	2.99	2.99
	65 x 40	73 x 48.3	20	76	76
7010504	2-1/2 x 2	2.875 x 2.375	300	2.99	2.99
	65 x 50	73 x 60.3	20	76	76
7010505	3 x 1-1/4	3.5 x 1.669	300	3.39	3.39
	80 x 32	88.9 x 42.4	20	86	86
7010506	3 x 1-1/2	3.5 x 1.9	300	3.39	3.39
	80 x 40	88.9 x 48.3	20	86	86
7010507	3 x 2	3.5 x 2.375	300	3.39	3.39
	80 x 50	88.9 x 60.3	20	86	86
7010508	3 x 2-1/2	3.5 x 2.875	300	3.39	3.39
	80 x 65	88.9 x 73	20	86	86
7010509	4 x 1-1/4	4.5 x 1.669	300	3.54	3.86
	100 x 32	114.3 x 42.4	20	90	98*
7010510	4 x 1-1/2	4.5 x 1.9	300	3.54	3.86
	100 x 40	114.3 x 48.3	20	90	98*
7010511	4 x 2	4.5 x 2.375	300	4.02	4.02
	100 x 50	114.3 x 60.3	20	102	102
7010512	4 x 2-1/2	4.5 x 2.875	300	4.02	4.02
	100 x 65	114.3 x 73	20	102	102
7010513	4 x 3	4.5 x 3.5	300	4.02	4.02
	100 x 80	114.3 x 88.9	20	102	102
7010514	5 x 2	5.56 x 2.375	300	4.13	4.13
	125 x 50	139.7 x 60.3	20	105	105
7010515	5 x 2-1/2	5.56 x 2.875	300	4.13	4.13
	125 x 65	139.7 x 76.1	20	105	105
7010518	5 x 3	5.56 x 3.5	300	4.13	4.13
	125 x 80	139.7 x 88.9	20	105	105
7010519	5 x 4	5.56 x 4.5	300	4.13	4.13
	125 x 100	139.7 x 108	20	105	105

Item #	Nominal Size in/mm	Pipe O.D. in/mm	Max Working Pressure psi/Bar	Dimensions	
				C1-E1 inches mm	C-E inches mm
7010522	6 x 2-1/2	6.25 x 2.875	300	4.33	4.72
	150 x 65	159 x 76.1	20	110	120
7010523	6 x 3	6.625 x 3.5	300	4.33	4.72
	150 x 80	159 x 88.9	20	110	120
7010524	6 x 4	6.625 x 4.5	300		
	150 x 100	159 x 88.9	20		

GROOVED END CAP, END CAP WITH HOLE

Model 601, 602



ARGCO Model 602 End Cap with Hole is an ideal transition fitting when a large reduction is required such as 6"×1", 4"×1" etc.

The Model 602 can be used as an alternative to expensive swaged nipples.



Pipe Material

- Carbon steel, Schedule 10, Schedule 40.

For use with alternative materials and wall thicknesses please contact ARGCO.

Maximum Working Pressure

- Up to 300 psi/20 bar

Function

- Joins carbon steel pipe.
- Provides a rigid pipe joint designed to restrict axial or angular movement.

CERTIFICATIONS/LISTINGS

Underwriters Laboratories, Underwriters Laboratories Canada, Factory Mutual.

SPECIFICATIONS - MATERIAL

Housing Sections: Ductile Iron conforming to ASTM A 536, Grade 65-45-12.

Housing Coating:

Standard: Orange Enamel

Available: Hot Dipped Galvanized

GROOVED END CAP, END CAP WITH HOLE

Model 601, 602

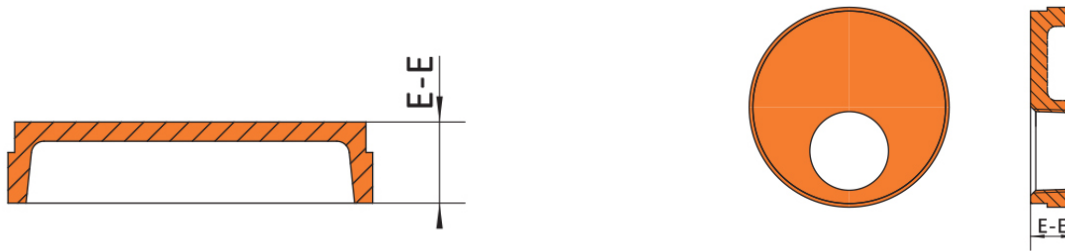

Item #	Nominal Size in/mm	Pipe O.D. in/mm	Max Working Pressure psi/Bar	E-E inches mm
7010125	1-1/4	1.669	300	0.94
	32	42.4	20	2.38
7010126	1-1/2	1.9	300	0.94
	40	48.3	20	2.38
7010127	2	2.375	300	0.94
	50	60.3	20	2.38
7010128	2-1/2	2.875	300	0.94
	65	76.1	20	2.38
7010129	3	3.5	300	0.94
	80	88.9	20	2.38
7010130	4	4.5	300	1.00
	100	114.3	20	25.4
7010131	5	5.56	300	1.00
	125	141.3	20	25.4
7010132	6	6.625	300	1.00
	150	168.3	20	25.4
7010133	8	8.625	300	1.19
	200	219.1	20	30.2
7010134	10	10.75	300	1.19
	250	273	20	30.2
7010135	12	12.75	300	1.19
	300	323.9	20	30.2

Item #	Nominal Size in/mm	Pipe O.D. in/mm	Max Working Pressure psi/Bar	E-E inches mm
7010136	2-1/2 x 1	2.875 x 1.315	300	0.94
	65 x 25	73 x 33.4	20	23.8
7010136A	2 x 1	2.375 x 1.327	300	0.94
	50 x 25	60.3 x 33.7	20	23.8
7010137	3 x 1	3.5 x 1.327	300	0.94
	80 x 25	88.9 x 33.7	20	23.8
7010138	4 x 1	4.5 x 1.327	300	1.00
	100 x 25	114.3 x 33.7	20	25.4
7010140	6 x 1	6.625 x 1.327	300	1.00
	150 x 25	168.3 x 33.7	20	25.4
7010141	8 x 1	8.65 x 1.327	300	
	200 x 25	219.1 x 33.4	20	

GROOVED CONCENTRIC REDUCER MODEL 701



Pipe Material

- Carbon steel, Schedule 10, Schedule 40.

For use with alternative materials and wall thicknesses please contact ARGCO.

Maximum Working Pressure

- Up to 300 psi/20 bar

Function

- Joins carbon grooved pipe system to flange components

CERTIFICATIONS/LISTINGS

Underwriters Laboratories, Underwriters Laboratories Canada, Factory Mutual.

SPECIFICATIONS - MATERIAL

Housing Sections: Ductile Iron conforming to ASTM A 536, Grade 65-45-12.

Housing Coating:

Standard: Orange Enamel

Available: Hot Dipped Galvanized

GROOVED CONCENTRIC REDUCER MODEL 701

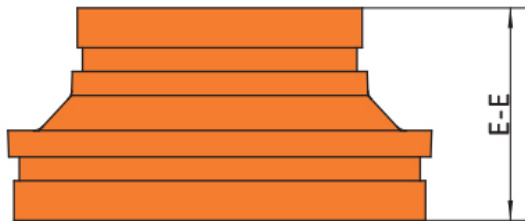

Item #	Nominal Size in/mm	Pipe O.D. in/mm	E-E in/mm
7010150	1-1/2 x 1-1/4 40 x 32	1.9 x 1.669 48.3 x 42.4	2.52 64
7010151	2 x 1" 50 x 25.4	2.375 x 1.315 60.3 x 42.4	2.52 64
7010152	2 x 1-1/4 50 x 32	2.375 x 1.669 60.3 x 42.4	2.52 64
7010153	2 x 1-1/2 50 x 40	2.375 x 1.9" 60.3 x 48.3	2.52 64
7010154	2-1/2 x 1-1/4 65 x 32	2.875 x 1.669 73 x 42.4	2.52 64
7010155	2-1/2 x 1-1/2 65 x 40	2.875 x 1.9 73 x 48.3	2.52 64
7010156	2-1/2 x 2 65 x 50	2.875 x 2.375 73 60.3	2.52 64
7010157	3 x 1-1/4 80 x 32	3.5 x 1.669 73 x 42.4	2.52 64
7010158	3 x 1-1/2 80 x 40	3.5 x 1.9 88.9 x 48.3	2.52 64
7010159	3 x 2 80 x 50	3.5 x 2.375 88.9 x 60.3	2.52 64
7010160	3 x 2-1/2 80 x 65	3.5 x 2.875 88.9 x 73	2.52 64
7010161	4 x 2" 100 x 50	4.5 x 2.375 114.3 x 60.3	2.99 76
7010162	4 x 2-1/2 100 x 65	4.5 x 2.875 114.3 x 73	2.99 76
7010163	4 x 3 100 x 80	4.5 x 3.5 114.3 x 88.9	2.99 76

Item #	Nominal Size in/mm	Pipe O.D. in/mm	E-E in/mm
7010164	5 x 2 125 x 50	5.56 x 2.375 133 x 60.3	3.35 85
7010165	5 x 3 125 x 80	5.56 x 3.5 139.7 x 88.9	3.35 85
7010166	5 x 4 125 x 100	5.56" x 4.5 139.7 x 114.3	3.35 85
7010167	6 x 2 150 x 50	6.625 x 2.375 159 x 60.3	3.35 85
7010167B	6 x 2-1/2 150 x 65	6.25 x 2.875 159 x 73	3.35 85
7010168	6 x 3 150 x 80	6.625" x 3.5 159 x 88.9	3.35 85
7010169	6 x 4 150 x 100	6.625" x 4.5 159 x 139.7	3.35 85
7010170	6 x 5 150 x 125	6.625 x 5.56 219.1 x 141.3	3.35 85
7010172	8 x 4 200 x 100	8.625 x 4.5 219.1 x 139.7	3.35 85
7010173	8 x 5 200 x 125	8.625 x 5.56 219.1 x 141.3	3.35 85
7010174	8 x 6 200 x 150	8.625 x 6.625 273 x 159	3.35 85
7010176	10 x 6 250 x 150	10.75 x 6.625 273 x 168.3	3.54 90
7010177	10 x 8 250 x 200	10.75 x 8.625 323.9 x 159	3.54 90
7010179	12 x 6 300 x 150	12.75 x 6.625 323.9 x 168.3	3.54 90
7010180	12 x 8 300 x 200	12.75 x 8.625 323.9 x 273	3.54 90
7010181	12 x 10 300 x 250	12.75 x 10.75 323.9 x 273.9	3.54 90

THREADED CONCENTRIC REDUCER

MODEL 702



ARGCO concentric reducers are cast of ductile iron. The end-to-end dimensions of these reducers are less than that of fabricated reducers.

Pipe Material

- Carbon steel, Schedule 10, Schedule 40.
For use with alternative materials and wall thicknesses please contact ARGCO.

Maximum Working Pressure

- Up to 250 psi/17 bar

Function

- Joins carbon grooved pipe system to flange components

CERTIFICATIONS/LISTINGS

Underwriters Laboratories, Underwriters Laboratories Canada, Factory Mutual.

SPECIFICATIONS - MATERIAL

Housing Sections: Ductile Iron conforming to ASTM A 536, Grade 65-45-12.

Housing Coating:

Standard: Orange Enamel

Available: Hot Dipped Galvanized

THREADED CONCENTRIC REDUCER MODEL 702

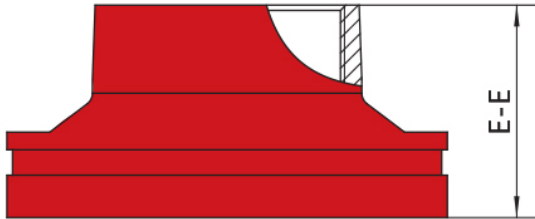

Item #	Nominal Size in/mm	Pipe O.D.	Max. Working Pressure PSI/Bar	E - E in/mm	Item #	Nominal Size in/mm	Pipe O.D. in/mm	Max. Working Pressure PSI/Bar	E-E in/mm
7010182	1-1/4" x 1" 32 x 3.4	1.669 x 1.315 42.4 x 33.4	230 16	2.25 16	7010198	4" x 2" 100 x 50	4.5 x 2.375 114.3 x 60.3	230 16	3.35 85
7010183	1-1/2" x 1-1/4" 40 x 32	1.9 x 1.669 48.3 x 42.4	230 16	2.25 16	7010199	4" x 3" 100 x 80	4.5 x 3.5 114.3 x 88.9	230 16	3.35 85
7010184	2" x 1" 50 x 25	2.375 x 1.327 60.3 x 33.7	230 16	2.25 16	7010200	5" x 1-1/4" 125 x 32	5.56 x 1.669 141.3 x 42.4	230 16	3.35 85
7010185	2" x 1-1/4" 50 x 32	2.375 x 1.669 60.3 x 42.4	230 16	2.25 16	7010201	5" x 1-1/2" 125 x 40	5.56 x 1.9 141.3 x 48.3	230 16	3.35 85
7010186	2" x 1-1/2" 50 x 40	2.375 x 1.9 60.3 x 48.3	230 16	2.25 64	7010202	5" x 2" 125 x 50	5.56 x 2.375 141.3 x 60.3	230 16	3.35 85
7010187	2-1/2" x 1-1/4" 65 x 32	2.875 x 1.669 73 x 42.4	230 16	2.52 64	7010203	5" x 3" 125 x 80	5.56 x 3.5 141.3 x 88.9	230 16	3.35 85
7010188	2-1/2" x 1-1/2" 65 x 40	2.875 x 1.9 73 x 48.3	230 16	2.52 64	7010204	6" x 1-1/4" 150 x 32	6.625 x 1.669 168.3 x 42.4	230 16	3.35 85
7010189	2-1/2" x 2" 65 x 50	2.875 x 2.375 73 x 60.3	230 16	2.52 64	7010205	6" x 1-1/2" 150 x 40	6.625 x 1.9 168.3 x 48.3	230 16	3.35 85
7010190	3" x 1" 80 x 25	3.5 x 1.315 88.9 x 33.4	230 16	2.52 64	7010206	6" x 2" 150 x 50	6.625 x 2.375 168.3 x 60.3	230 16	3.35 85
7010191	3" x 1-1/4" 80 x 32	3.5 x 1.669 88.9 x 42.4	230 16	2.52 64	7010207	6" x 2-1/2" 150 x 65	6.625 x 2.875 168.3 x 73.0	230 16	3.35 85
7010192	3" x 1-1/2" 80 x 40	3.5 x 1.9 88.9 x 48.3	230 16	2.52 64	7010208	6" x 3" 150 x 80	6.625 x 3.5 168.3 x 88.9	230 16	3.35 85
7010193	3" x 2" 80 x 50	3.5 x 2.375 88.9 x 60.3	230 16	2.52 64	7010209	8" x 1" 200 x 25	8.625 x 1.327 219.1 x 33.7	230 16	3.35 85
7010194	3" x 2-1/2" 80 x 65	3.5 x 2.875 88.9 x 73.0	230 16	2.52 64	7010210	8" x 1-1/4" 200 x 32	8.625 x 1.669 219.1 x 42.4	230 16	3.35 85
7010195	4" x 1" 100 x 25	4.5 x 1.327 114.3 x 33.7	230 16	2.99 76	7010211	8" x 1-1/2" 200 x 40	8.625 x 1.9 219.1 x 48.3	230 16	3.35 85
7010196	4" x 1-1/4" 100 x 32	4.5 x 1.669 114.3 x 42.4	230 16	2.99 76	7010212	8" x 2" 200 x 50	8.625 x 2.375 219.1 x 60.3	230 16	3.35 85
7010197	4" x 1-1/2" 100 x 40	4.5 x 1.9 114.3 x 48.3	230 16	2.99 76	7010213	8" x 2-1/2" 200 x 65	8.625 x 2.875 219.1 x 73	230 16	3.35 85

U-BOLT MECHANICAL TEE (SADDLE-LET)

Model 501



The Model 300U Saddle-Lets is the ideal outlet fitting for direct connections to sprinkler heads, drop nipples and or gauges. No need for welding, just cut or drill a hole at the desired outlet location. Position the Saddle-Let so that the locating collar fits within the hole and secure with the U-bolt and nuts. The Saddle-Let allows full bore flow and is pressure rates to 300 psi (20 bar).

Pipe Material

- Carbon steel, Schedule 10, Schedule 40.

For use with alternative materials and wall thicknesses please contact ARGCO.

Maximum Working Pressure

- Up to 300 psi/2517 kPa.

Function

- Joins carbon steel pipe.
- Provides a rigid pipe joint designed to restrict axial or angular movement.

CERTIFICATIONS/LISTINGS

Underwriters Laboratories, Underwriters Laboratories Canada, Factory Mutual.

SPECIFICATIONS - MATERIAL

Housing Sections: Ductile Iron conforming to ASTM A 536, Grade 65-45-12.

Housing Coating:

Standard: Orange Enamel

Available: Hot Dipped Galvanized

Gasket:

Standard: Grade E EPDM (Type A)

ARGCO's products are listed by Underwriters Laboratories UL Canada and Approved by Factory Mutual for wet and dry (oil free air) sprinkler services within the rated working pressure.

Bolts and Nuts

Standard: Carbon Steel oval neck track bolts meeting ASTM A449 and ISO 898-1. Carbon steel hex nuts meet ASTM A563 Grade B.

Nuts and Bolts are zinc electroplated per ASTM B633 NZ/FE5, finish Type III.

Available: Stainless Steel. Meets ASTM F593, Group 2 (316 stainless steel), condition CW.

Hex nuts meets ASTM F594, Group 2 (316 stainless steel), condition CW, with galling-resistant coating.

U-BOLT MECHANICAL TEE (SADDLE-LET)

Model 501

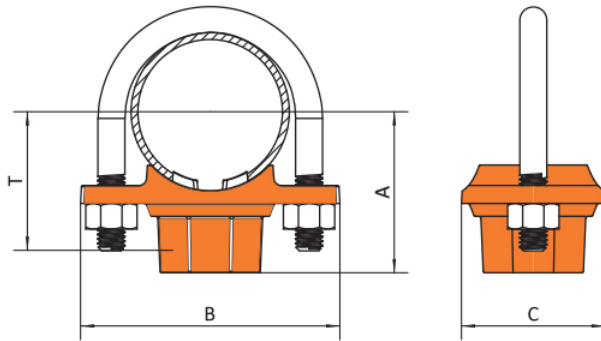

Item #	Nominal Size in/mm	Hole Dia. T +0.04, -0 +1, -0	Hole Saw Size in/mm	Dimensions			Take-Out T/D in/mm	Bolt Size in	Bolt Torque N-M/Lbs-Ft
				A inches mm	B inches mm	C inches mm			
7010285	1-1/4 x 1/2	1.18	1-3/16	2.09	3.50	2.20	1.73	3/8	22-29
	32 x 15	30	30	53	89	56	44	U-Bolt	30-40
7010286	1-1/4 x 3/4	1.18	1-3/16	2.09	3.50	2.20	1.73	3/8	22-29
	32 x 20	30	30	53	89	56	44	U-Bolt	30-40
7010287	1-1/4 x 1	1.18	1-3/16	2.20	3.50	2.20	1.85	3/8	22-29
	32 x 25	30	30	56	89	56	47	U-Bolt	30-40
7010288	1-1/2 x 1/2	1.18	1-3/16	2.17	3.50	2.20	1.81	3/8	22-29
	40 x 15	30	30	55	89	56	46	U-Bolt	30-40
7010289	1-1/2 x 3/4	1.18	1-3/16	2.17	3.50	2.20	1.81	3/8	22-29
	40 x 20	30	30	55	89	56	46	U-Bolt	30-40
7010290	1-1/2 x 1	1.18	1-3/16	2.28	3.50	2.20	1.93	3/8	22-29
	40 x 25	30	30	58	89	56	49	U-Bolt	30-40
7010291	2 x 1/2	1.18	1-3/16	2.52	3.86	2.20	2.09	3/8	22-29
	50 x 15	30	30	64	98	56	53	U-Bolt	30-40
7010292	2 x 3/4	1.18	1-3/16	2.52	3.86	2.20	2.09	3/8	22-29
	50 x 20	30	30	64	98	56	53	U-Bolt	30-40
7010293	2 x 1	1.18	1-3/16	2.64	3.86	2.20	2.20	3/8	22-29
	50 x 25	30	30	67	98	56	56	U-Bolt	30-40
7010294	2-1/2 x 1/2	1.18	1-3/16	2.72	4.37	2.20	2.28	3/8	22-29
	65 x 15	30	30	69	111	56	58	U-Bolt	30-40
7010295	2-1/2 x 3/4	1.18	1-3/16	2.72	4.37	2.20	2.28	3/8	22-29
	65 x 20	30	30	69	111	56	58	U-Bolt	30-40
7010296	2-1/2 x 1	1.18	1-3/16	2.83	4.37	2.20	2.40	3/8	22-29
	65 x 25	30	30	72	111	56	61	U-Bolt	30-40

MECHANICAL TEE (THREAD)

Model 403



The Model 302 Mechanical Tee provides a fast and easy mid-pipe threaded branch outlet. It eliminates the need for welding or multiple fittings. The mechanical tee utilizes ductile iron housings, a grade E moulded gasket and heat-treated carbon steel track bolts and nuts. Pressure rated to 300 psi (20 bar).

Pipe Material

- Carbon steel, Schedule 10, Schedule 40.

For use with alternative materials and wall thicknesses please contact ARGCO.

Maximum Working Pressure

- Up to 300 psi/20 bar

Function

- Joins carbon steel pipe.
- Provides a rigid pipe joint designed to restrict axial or angular movement.

CERTIFICATIONS/LISTINGS

Underwriters Laboratories, Underwriters Laboratories Canada, Factory Mutual.

SPECIFICATIONS - MATERIAL

Housing Sections: Ductile Iron conforming to ASTM A 536, Grade 65-45-12.

Housing Coating:

Standard: Orange Enamel

Available: Hot Dipped Galvanized

Gasket:

Standard: Grade E EPDM (Type A)

ARGCO's products are listed by Underwriters Laboratories UL Canada and Approved by Factory Mutual for wet and dry (oil free air) sprinkler services within the rated working pressure.

Bolts and Nuts

Standard: Carbon Steel oval neck track bolts meeting ASTM A449 and ISO 898-1. Carbon steel hex nuts meet ASTM A563 Grade B.

Nuts and Bolts are zinc electroplated per ASTM B633 NZ/FE5, finish Type III.

Available: Stainless Steel. Meets ASTM F593, Group 2 (316 stainless steel), condition CW.

Hex nuts meet ASTM F594, Group 2 (316 stainless steel), condition CW, with galling-resistant coating.

MECHANICAL TEE (THREAD)

Model 403

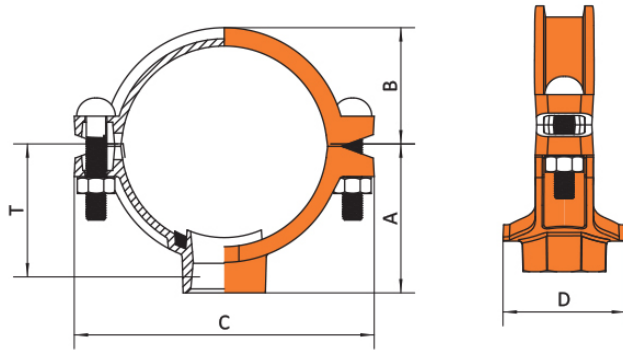

Item #	Nominal Size in/mm	Pipe O.D.	Hole Dia. \pm +3.2,-0 /+0.13,-0	Dimensions - in/mm					Bolt Size in/mm
				T \ddagger	A	B	C	D	
7010302	2 x 3/4	2.375 x 1.05	1.50	1.97	2.20	1.65	4.72	2.99	3/8 x 2-3/8
	50 x 20	60.3 x 26.7	38	50	56	42	120	76	M 10 x 60
7010303	2-1/2 x 3/4	2.875 x 1.05	1.50	2.02	2.42	1.85	5.63	2.99	1/2 x 2-5/8
	65 x 20	73 x 26.7	38	56	61.5	47	143	76	M 12 x 65
7010304	2 x 1	2.375 x 1.315	1.50	1.85	2.20	1.65	4.72	2.99	3/8 x 2-3/8
	50 x 25	60.3 x 33.7	38	47	56	42	120	76	M 10 x 60
7010305	2 x 1-1/4	2.375 x 1.669	1.75	2.05	2.68	1.65	4.72	3.31	3/8 x 2-3/8
	50 x 32	60.3 x 42.4	44.5	52	68	42	120	84	M 10 x 60
7010306	2 x 1-1/2	2.375 x 1.9	1.75	2.05	2.80	1.65	4.72	3.37	3/8 x 2-3/8
	50 x 40	60.3 x 48.3	44.5	52	71	42	120	84	M 10 x 60
7010307	2-1/2 x 1	2.875 x 1.327	1.50	2.09	4.42	1.85	5.63	2.99	1/2 x 2-5/8
	65 x 25	73 x 33.7	38	53	61.5	47	143	76	M 12 x 65
7010308	2-1/2 x 1-1/4	2.875 x 1.669	1.75	2.28	2.89	1.85	5.63	3.31	1/2 x 2-5/8
	65 x 32	73 x 42.4	44.5	58	73.5	47	143	84	M 12 x 65
7010309	2-1/2 x 1-1/2	2.875 x 1.9	2.00	2.28	2.89	1.85	5.63	3.54	1/2 x 2-5/8
	65 x 40	73 x 48.3	50.8	58	73.5	47	143	90	M 12 x 65
7010311	3 x 1	3.5 x 1.327	1.50	2.40	2.74	2.17	6.22	2.99	1/2 x 2-5/8
	80 x 25	88.9 x 33.7	38	61	69.5	55	158	76	M 12 x 65
7010312	3 x 1-1/4	3.5 x 1.669	1.75	2.56	3.19	2.17	6.22	3.31	1/2 x 2-5/8
	80 x 32	88.9 x 42.4	44.5	65	81	55	158	84	M 12 x 65
7010313	3 x 1-1/2	3.5 x 1.9	2.00	2.80	3.19	2.17	6.22	3.54	1/2 x 2-5/8
	80 x 40	88.9 x 48.3	50.8	71	81	55	158	90	M 12 x 65
7010314	3 x 2	3.5 x 2.375	2.50	2.76	3.19	2.17	6.22	3.98	1/2 x 2-5/8
	80 x 50	88.9 x 60.3	63.5	70	81	55	158	101	M 12 x 65
7010315	4 x 1	4.5 x 1.327	1.50	2.87	2.99	2.44	6.57	2.99	1/2 x 2-5/8
	100 x 25	114.3 x 33.7	38	73	76	62	167	76	M 12 x 65
7010316	4 x 1-1/4	4.5 x 1.669	1.81	3.07	2.99	2.44	6.57	3.27	1/2 x 2-5/8
	100 x 32	114.3 x 42.4	46	78	76	62	167	83	M 12 x 65
7010317	4 x 1-1/2	4.5 x 1.9	2.09	3.27	2.99	2.44	6.57	3.54	1/2 x 2-5/8
	100 x 40	114.3 x 48.3	53	83	76	62	167	90	M 12 x 65
7010318	4 x 2	4.5 x 2.375	2.50	3.27	3.07	2.44	6.57	3.94	1/2 x 2-5/8
	100 x 50	114.3 x 60.3	63.5	83	78	62	167	100	M 12 x 65
7010319	4 x 2-1/2	4.5 x 2.875	2.76	2.87	4.13	2.44	6.57	4.61	1/2 x 2-5/8
	100 x 65	114.3 x 73.0	70	73	105	62	167	117	M 12 x 65

Continued on next page

MECHANICAL TEE (THREAD)

Model 403

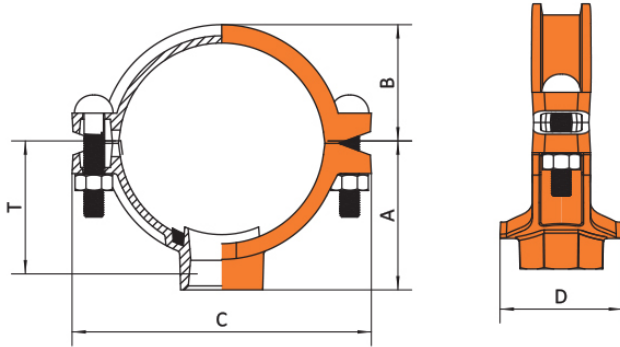

Item #	Nominal Size in/mm	Pipe O.D.	Hole Dia. \mp +3.2,-0 /+0.13,-0	Dimensions - in/mm					Bolt Size in/mm
				T _t	A	B	C	D	
7010321	4 x 3	4.5 x 3.5	3.50	3.31	3.94	2.56	7.13	5.35	1/2 x 2-3/4
	100 x 80	114.3 x 88.9	89	84	100	65	181	136	M 12 x 70
7010322	5 x 1	5.56 x 1.327	1.50	3.35	3.50	2.91	8.07	2.99	1/2 x 3
	125 x 25	141.2 x 33.4	38	85	89	74	205	76	M 12 x 75
7010323	5 x 1-1/4	5.56 x 1.669	1.81	3.54	3.50	2.91	8.07	3.27	1/2 x 3
	125 x 32	141.3 x 42.4	46	90	89	74	205	83	M 12 x 75
7010324	5 x 1-1/2	5.56 x 1.9	2.09	3.74	3.50	2.91	8.07	3.54	1/2 x 3
	125 x 40	141.3 x 48.3	53	95	89	74	205	90	M 12 x 75
7010325	5 x 2	5.56 x 2.375	2.52	3.74	3.50	2.91	8.07	3.94	1/2 x 3
	125 x 50	141.3 x 60.3	64	95	89	74	205	100	M 12 x 75
7010326	5 x 2-1/2	5.56 x 2.875	3.15	3.82	3.62	2.91	8.07	4.61	1/2 x 3
	125 x 65	141.3 x 73.0	80	97	92	74	205	117	M 12 x 75
7010327	5 x 3	5.56 x 3.5	3.62	4.17	3.70	2.91	8.07	5.08	1/2 x 3
	125 x 80	141.3 x 88.9	92	106	94	74	205	129	M 12 x 75
7010328	6 x 1	6.625 x 1.327	1.50	4.45	4.00	3.58	9.17	2.99	9/16 x 3
	150 x 25	168.3 x 33.4	38	113	101.5	91	233	76	M 14 x 75
7010329	6 x 1-1/4	6.625 x 1.669	1.81	4.45	4.00	3.58	9.17	3.27	1/2 x 3
	150 x 32	168.3 x 42.4	46	113	101.5	91	233	83	M 12 x 75
7010330	6 x 1-1/2	6.625 x 1.9	2.09	4.41	4.00	3.58	9.17	3.54	1/2 x 3
	150 x 40	168.3 x 48.3	53	112	101.5	91	233	90	M 12 x 75
7010331	6 x 2	6.625 x 2.375	2.52	4.37	4.00	3.58	9.17	3.94	1/2 x 3
	150 x 50	168.3 x 60.3	64	111	101.5	91	233	100	M 12 x 75
7010332	6 x 2-1/2	6.625 x 2.875	3.15	4.37	4.15	3.58	9.17	4.61	5/8 x 3-1/3
	150 x 65	168.3 x 73.0	80	111	105.5	91	233	117	M 16 x 85
7010333	6 x 3	6.625 x 3.5	3.62	4.33	4.15	3.58	9.17	5.08	5/8 x 3-1/3
	150 x 80	168.3 x 88.9	92	110	105.5	91	233	129	M 16 x 85
7010334	8 x 1	8.625 x 1.327	1.50	5.98	5.35	1.92	12.68	2.99	5/8 x 3-1/2
	200 x 25	219.1 x 33.4	38	152	136	125	322	76	M 20 x 90
7010335	8 x 1-1/4	8.625 x 1.669	1.75	5.98	5.79	1.92	12.68	3.31	5/8 x 3-1/2
	200 x 32	219.9 x 42.4	44.5	152	147	125	322	84	M 20 x 90
7010336	8 x 1-1/2	8.625 x 1.9	2.00	5.98	5.79	1.92	12.68	3.54	5/8 x 3-1/2
	200 x 40	219.1 x 48.3	50.8	152	147	125	322	90	M 20 x 90
7010337	8 x 2	8.625 x 2.375	2.50	5.43	5.79	1.92	12.68	3.98	5/8 x 3-1/2
	200 x 50	219.1 x 60.3	63.5	138	147	125	322	101	M 20 x 90
7010338	8 x 2-1/2	8.625 x 2.875	2.76	5.08	6.14	1.92	12.68	4.61	5/8 x 3-1/2
	200 x 65	219.1 x 73.0	70	129	156	125	322	117	M 20 x 90
7010339	8 x 3	8.625 x 3.5	3.50	5.31	6.24	1.92	12.68	136	5/8 x 3-1/2
	200 x 80	219.1 x 88.9	89	135	158.5	125	322	5.35	M 20 x 90

SADDLE-LET SMALL MECHANICAL TEE (THREAD)

Model 502



The Model 502 Saddle-Lets is the ideal outlet fitting for direct connections to sprinkler heads, drop nipples and or gauges.

No need for welding, just cut or drill a hole at the desired outlet location.

Position the Saddle-Let so that the locating collar fits within the hole and secure with the U-bolt and nuts.

The Saddle-Let allows full bore flow and is pressure rates to 300 psi (20 bar).

Pipe Material

- Carbon steel, Schedule 10, Schedule 40.

For use with alternative materials and wall thicknesses please contact ARGCO.

Maximum Working Pressure

- Up to 300 psi/20 bar

Function

- Joins carbon steel pipe.
- Provides a rigid pipe joint designed to restrict axial or angular movement.

CERTIFICATIONS/LISTINGS

Underwriters Laboratories, Underwriters Laboratories Canada, Factory Mutual.

SPECIFICATIONS - MATERIAL

Housing Sections: Ductile Iron conforming to ASTM A 536, Grade 65-45-12.

Housing Coating:

Standard: Orange Enamel

Available: Hot Dipped Galvanized

Gasket:

Standard: Grade E EPDM (Type A)

ARGCO's products are listed by Underwriters Laboratories UL Canada and Approved by Factory Mutual for wet and dry (oil free air) sprinkler services within the rated working pressure.

Bolts and Nuts

Standard: Carbon Steel oval neck track bolts meeting ASTM A449 and ISO 898-1. Carbon steel hex nuts meet ASTM A563 Grade B.

Nuts and Bolts are zinc electroplated per ASTM B633 NZ/FE5, finish Type III.

Available: Stainless Steel. Meets ASTM F593, Group 2 (316 stainless steel), condition CW.

Hex nuts meets ASTM F594, Group 2 (316 stainless steel), condition CW, with galling-resistant coating.

SADDLE-LET SMALL MECHANICAL TEE (THREAD)

Model 502

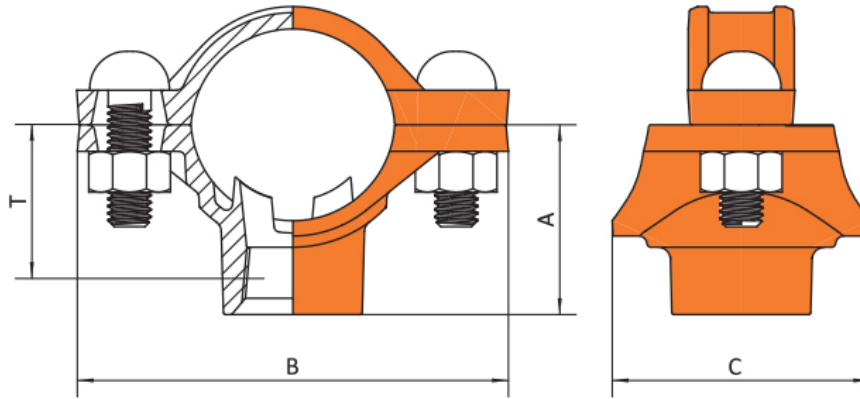

Item #	Nominal Size in/mm	Hole Dia. T +0.04, -0 +1, -0	Hole Saw Size in/mm	Dimensions			Take-Out T/D in/mm	Bolt Size in	Bolt Torque N-M/Lbs-Ft
				A inches mm	B inches mm	C inches mm			
7010300	1 x 1-1/2	0.95	15/16	1.10	3.66	1.89	1.14	3/8	22-29
100050	25 x 40	24	24	28	93	48	29		30-40
7010300	1-1/4 x 1/2	1.18	1-3/16	1.77	3.86	2.56	1.30	3/8	22-29
125050	35 x 15	30	30	45	98	65	33		30-40
7010300	1-1/4 x 3/4	1.18	1-3/16	1.77	3.86	2.56	1.28	3/8	22-29
125075	32 x 20	30	30	45	98	65	32.5		30-40
7010300	1-1/4 x 1	1.18	1-3/16	2.13	3.86	2.20	1.52	3/8	22-29
125100	32 x 25	30	30	54	98	56	38.6		30-40
7010300	1-1/2 x 1/2	1.18	1-3/16	1.89	3.86	2.20	1.42	3/8	22-29
150050	40 x 15	30	30	48	98	56	36.1		30-40
7010300	1-1/2 x 3/4	1.18	1-3/16	1.89	3.86	2.20	1.40	3/8	22-29
150075	40 x 20	30	30	48	98	56	35.6		30-40
7010300	1-1/2 x 1	1.18	1-3/16	2.24	3.86	2.20	1.64	3/8	22-29
150100	40 x 25	30	30	57	98	56	41.7		30-40
7010300	2 x 1/2	1.18	1-3/16	2.13	3.86	2.20	1.66	3/8	22-29
200050	50 x 15	30	30	54	98	56	42.2		30-40
7010300	2 x 3/4	1.18	1-3/16	2.13	3.86	2.20	1.64	3/8	22-29
200075	50 x 20	30	30	54	98	56	41.7		30-40
7010300	2 x 1	1.18	1-3/16	2.44	3.86	2.20	1.88	3/8	22-29
200100	50 x 25	30	30	62	98	56	47.8		30-40
7010300	2-1/2 x 1/2	1.18	1-3/16	2.40	3.86	2.20	1.91	3/8	22-29
250005	65 x 15	30	30	61	98	56	48.5		30-40
7010300	2-1/2 x 3/4	1.18	1-3/16	2.40	3.86	2.20	1.89	3/8	22-29
250075	65 x 20	30	30	61	98	56	48		30-40
7010300	2-1/2 x 1	1.18	1-3/16	2.80	3.86	2.20	2.13	3/8	22-29
250100	65 x 25	30	30	71	98	56	54.1		30-40

MECHANICAL TEE (GROOVE)

Model 402



The Model 301 Mechanical Tee provides a fast and easy mid-pipe grooved branch outlet. The mechanical tee utilizes ductile iron housings, a grade E gasket and heat-treated carbon steel track bolts and nuts. Maximum working pressure: 300 psi (20 bar).

Pipe Material

- Carbon steel, Schedule 10, Schedule 40.

For use with alternative materials and wall thicknesses please contact ARGCO.

Maximum Working Pressure

- Up to 300 psi/20 bar

Function

- Joins carbon steel pipe.
- Provides a rigid pipe joint designed to restrict axial or angular movement.

CERTIFICATIONS/LISTINGS

Underwriters Laboratories, Underwriters Laboratories Canada, Factory Mutual.

SPECIFICATIONS - MATERIAL

Housing Sections: Ductile Iron conforming to ASTM A 536, Grade 65-45-12.

Housing Coating:

Standard: Orange Enamel

Available: Hot Dipped Galvanized

Gasket:

Standard: Grade E EPDM (Type A)

ARGCO's products are listed by Underwriters Laboratories UL Canada and Approved by Factory Mutual for wet and dry (oil free air) sprinkler services within the rated working pressure.

Bolts and Nuts

Standard: Carbon Steel oval neck track bolts meeting ASTM A449 and ISO 898-1. Carbon steel hex nuts meet ASTM A563 Grade B.

Nuts and Bolts are zinc electroplated per ASTM B633 NZ/FE5, finish Type III.

Available: Stainless Steel. Meets ASTM F593, Group 2 (316 stainless steel), condition CW.

Hex nuts meets ASTM F594, Group 2 (316 stainless steel), condition CW, with galling-resistant coating.

MECHANICAL TEE (GROOVE)

Model 402

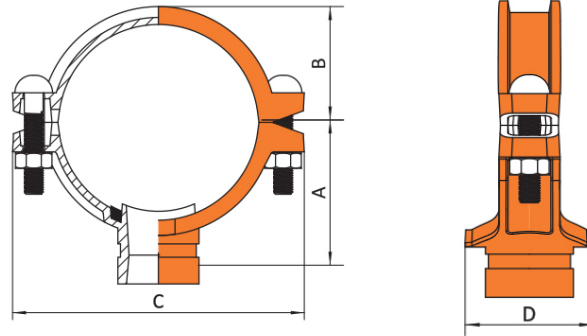

Item #	Nominal Size in/mm	Pipe O.D.	Hole Dia. \mp +3.2,-0 /+0.13,-0	Dimensions - in/mm				Bolt Size in/mm
				A	B	C	D	
7010415	2 x 1-1/4	2.375 x 1.669	1.75	2.85	1.65	4.72	3.31	3/8 x 2-3/8
	50 x 32	60.3 x 42.4	44.5	72.5	42	120	84	M 10 x 60
7010416	2 x 1-1/2	2.375 x 1.9	1.75	2.85	1.65	4.72	3.31	3/8 x 2-3/8
	50 x 40	60.3 x 42.4	44.5	72.5	42	120	84	M 10 x 60
7010417	2-1/2 x 1-1/4	2.875 x 1.669	1.75	3.09	1.85	5.63	3.31	1/2 x 2-5/8
	65 x 32	73 x 42.4	44.5	78.5	47	143	84	M 12 x 65
7010418	2-1/2 x 1-1/2	2.875 x 1.9	2.00	3.09	1.85	5.63	3.54	1/2 x 2-5/8
	65 x 40	73 x 48.3	50.8	78.5	47	143	90	M 12 x 65
7010420	3 x 1-1/4	3.5 x 1.669	1.72	3.39	2.17	6.22	3.31	1/2 x 2-5/8
	80 x 32	88.9 x 42.4	44.5	86	55	158	84	M 12 x 65
7010421	3 x 1-1/2	3.5 x 1.9	2.00	3.39	2.17	6.22	3.54	1/2 x 2-5/8
	80 x 40	88.9 x 48.3	50.8	86	55	158	90	M 12 x 65
7010422	3 x 2	3.5 x 2.375	2.50	3.43	2.17	6.22	3.98	1/2 x 2-5/8
	80 x 50	88.9 x 60.3	63.5	87	55	158	101	M 12 x 65
7010424	4 x 1-1/4	4.5 x 1.669	1.75	3.90	2.56	7.13	3.31	1/2 x 2-3/4
	100 x 32	114.3 x 42.4	44.5	99	65	181	84	M 12 x 70
7010425	4 x 1-1/2	4.5 x 1.9	2.00	3.90	2.56	7.13	3.54	1/2 x 2-3/4
	100 x 40	114.3 x 48.3	50.8	99	65	181	90	M 12 x 70
7010426	4 x 2	4.5 x 2.375	2.52	3.64	2.44	6.77	3.54	1/2 x 2-5/8
	100 x 50	108 x 60.3	64	92.5	62	172	90	M 12 x 65
7010427	4 x 2-1/2	4.5 x 2.875	2.75	3.64	2.44	6.77	4.21	1/2 x 2-5/8
	100 x 65	114.3 x 73.0	70	92.5	62	172	107	M 12 x 65
7010428	4 x 3	4.5 x 3.5	3.50	3.90	2.56	7.13	5.35	1/2 x 2-3/4
	100 x 80	114.3 x 88.9	89	99	65	181	136	M 12 x 70
7010435	6 x 1-1/4	6.625 x 1.669	1.75	4.92	3.7	9.76	3.31	9/16 x 3
	150 x 32	168.3 x 42.4	44.5	125	94	248	84	M 14 x 75
7010436	6 x 1-1/2	6.625 x 1.9	2.00	4.92	3.7	9.76	3.54	5/8 x 3-1/3
	150 x 40	168.3 x 48.3	50.8	125	94	248	90	M 16 x 85
7010437	6 x 2	6.625 x 2.375	2.52	4.65	3.58	9.71	3.94	9/16 x 3
	150 x 50	168.3 x 60.3	64	118	91	233	100	M 14 x 75
7010438	6 x 2-1/2	6.625 x 2.875	2.75	4.65	3.58	9.17	4.61	9/16 x 3
	150 x 65	168.3 x 63.5	70	118	91	233	117	M 14 x 75
7010439	6 x 3	6.625 x 3.5	3.62	4.65	3.58	9.17	5.08	9/16 x 3
	150 x 80	168.3 x 88.9	92	118	91	233	129	M 14 x 75
7010440	6 x 4	6.625 x 4.5	4.09	4.70	3.58	9.17	5.63	9/16 x 3
	150 x 100	168.3 x 114.3	104	119.5	91	233	143	M 14 x 75
7010443	8 x 2	8.625 x 2.375	2.50	5.98	1.92	12.68	3.98	5/8 x 3-1/2
	200 x 50	219.1 x 60.3	63.5	152	125	322	101	M 20 x 90
7010444	8 x 2-1/2	8.625 x 2.875	2.75	6.06	1.92	12.68	4.61	5/8 x 3-1/2
	200 x 65	219.1 x 63.5	70	154	125	322	117	M 20 x 90
7010445	8 x 3	8.625 x 3.5	3.50	6.06	1.92	12.68	5.35	5/8 x 3-1/2
	200 x 80	219.1 x 88.9	89	154	125	322	136	M 20 x 90

FLANGE ADAPTER

Model 901



The Model 901 Flange Adapter allows for direct connection of a grooved system to ANSI class 125/150 flanged components

SPECIFICATIONS - MATERIAL

Housing Sections: Ductile Iron conforming to ASTM A 536, Grade 65-45-12.

Housing Coating:

Standard: Orange Enamel
Available: Hot Dipped Galvanized

Bolts and Nuts

Standard: Carbon Steel oval neck track bolts meeting ASTM A449 and ISO 898-1. Carbon steel hex nuts meet ASTM A563 Grade B. Nuts and Bolts are zinc electroplated per ASTM B633 NZ/FE5, finish Type III.

Pipe Material

- Carbon steel, Schedule 10, Schedule 40.

Maximum Working Pressure

- Up to 300 psi/20 bar

Function

- Joins carbon grooved pipe system to flange components

CERTIFICATIONS/LISTINGS

Underwriters Laboratories,
Underwriters Laboratories Canada, Factory Mutual.

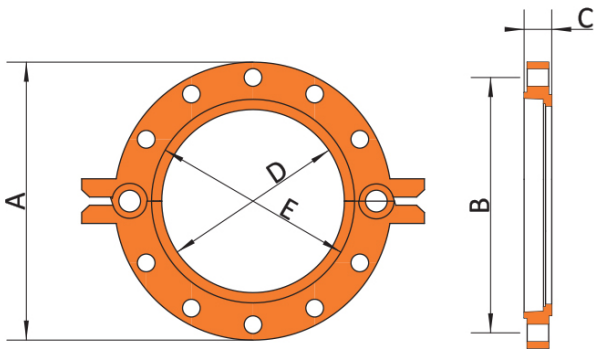

Item #	Nominal Size in/mm	Pipe O.D. in/mm	Max. Working Pressure PSI/Bar	Max. End Load Lbs./KN	A inches mm	B inches mm	C inches mm	D inches mm	E inches mm	Bolt Holes No.	Bolt Size in/mm
7010450	2	2.375	250	1330	6.10	4.74	0.98	2.36	3.07	4	5/8
	50	60.3	17	5.71	155	120.5	25	60	78	4	M16
7010451	2-1/2	2.875	250	1950	7.09	5.51	0.98	2.87	3.66	4	5/8
	65	73.0	17	8.37	180	140	25	73	93	4	M16
7010452	3	3.500	250	2880	7.48	6.02	0.98	3.50	4.21	8	5/8
	80	88.9	17	12.41	190	153	25	89	107	8	M16
7010453	4	4.500	250	4770	9.06	7.52	0.98	4.49	5.16	8	5/8
	100	114.3	17	20.51	230	191	25	114	131	8	M16
7010454	5	5.563	250	7390	10.04	8.50	0.98	5.55	6.18	8	3/4
	125	141.3	17	31.35	255	216	25	141	157	8	M20
7010455	6	6.625	250	10340	11.02	9.49	0.98	6.61	7.28	8	3/4
	150	168.3	17	44.47	280	241	25	168	185	8	M20
7010456	8	8.625	250	17520	13.58	11.77	1.06	8.62	9.21	8	3/4
	200	219.1	17	75.37	345	299	27	219	234	8	M20
7010457	10	10.750	250	27210	15.94	14.25	1.18	10.75	11.57	12	1
	250	237.0	17	164.71	405	362	30	273	294	12	M24
7010458	12	12.75	250	38280	19.09	17.01	1.26	12.76	13.43	12	1
	300	323.9	17	164.71	485	432	32	324	341	12	M24

FLANGE ADAPTER NIPPLE

Model 802



The Model 902 Flange Adapter Nipple provides a rigid transition from a flanged component to a grooved system.

Pipe Material

- Carbon steel, Schedule 10, Schedule 40.

Maximum Working Pressure

- Up to 300 psi/20\ bar

Function

- Joins carbon grooved pipe system to flange components

CERTIFICATIONS/LISTINGS

Underwriters Laboratories,
Underwriters Laboratories Canada,
Factory Mutual.

SPECIFICATIONS - MATERIAL

Housing Sections: Ductile Iron
conforming to ASTM A 536, Grade 65-45-12.

Housing Coating:

Standard: Orange Enamel
Available: Hot Dipped Galvanized

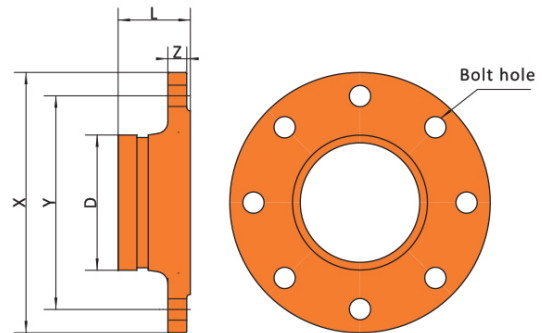

Item #	Nominal Size in/mm	Pipe O.D. in/mm	Max. Working Pressure PSI/Bar	Dimensions				Bolt Holes No.	Bolt Size in/mm
				X inches mm	Y inches mm	Z inches mm	L inches mm		
	2	2.375	300	6.10	4.74	0.63	2.56	4	5/8
	50	60.3	20	155	120.5	16	65	4	M16
7010630	2-1/2	2.875	300	7.09	5.51	0.63	2.56	4	5/8
	65	73.0	20	180	140	16	65	4	M16
7010631	3	3.50	300	7.48	6.02	0.71	2.65	4	5/8
	80	88.90	20	190	153	18	65	4	M16
7010632	4	4.50	300	9.06	7.52	0.87	2.76	8	5/8
	100	114.30	20	230	191	22	70	8	M16
7010633	5	5.563	300	10.04	8.50	0.87	2.76	8	3/4
	125	141.3	20	255	216	22	70	8	M20
7010634	6	6.625	300	11.02	9.49	0.87	2.76	8	3/4
	150	168.30	20	280	241	22	70	8	M20
7010635	8	8.625	300	13.58	11.77	0.98	3.15	8	3/4
	200	219.1	20	345	299	25	80	8	M20
7010636	10	10.75	300	15.94	14.25	1.02	3.95	12	1
	250	273	20	405	362	26	85	12	M24
7010637	12	12.75	300	19.09	17.01	1.10	3.95	12	1
	300	323.9	20	485	432	28	90	12	M24

GASKET SELECTION GUIDE FOR GROOVED



GASKET SELECTION GUIDE

ARGCO utilizes the finest gasket materials available in our products. Over the past 50 year great advances have been made in synthetic elastomer technologies, allowing us to offer a full range of synthetic rubber gasket materials for a wide variety of piping applications. ARGCO gaskets are engineered and designed to meet and exceed standards such as ASTM D2000, AWWA C606, NSF61 and IAPMO. Our own stringent internal laboratory testing confirms this. Our continual research, development and testing are designed to advance the elastomer field and to develop better solutions for our ever changing industry.

Chemical resistance is primarily determined by the grade and or the compound of the gasket. The color coding identifies the gasket grade and or compound. Always verify that the gasket selected is correct for the intended service. Service temperature is controlled by factors including the gasket compound, fluid medium (air, water, oils, etc.), and continuity (continuous or intermittent) of service. Under no circumstances should gaskets be exposed to temperatures above or below their individual ratings.

Standard Gaskets

Compound	Grade	Color Dode	Recommended Services	Maximum Temp. Range
EPDM	E	Green Stripe	Good for cold & hot water up to +230°F (+110°C). Also good for services for water with acid, water with chlorine, deionized water, seawater and waste water, dilute acids, oil-free air and many chemicals. Not recommended for petroleum oils, solvents and aromatic hydrocarbons.	-29°F (-34°C) to +230°F (+110°C)
Nitrile	T	Orange Stripe	Good for petroleum oils, mineral oils, vegetable oils, aromatic hydrocarbons, many acids and water ≤ +150°F (+65°C).	-20°F (-29°C) to +180°F (+82°C)
White Nitrile	A	White Gasket	Good for oily and greasy food products and processing, as well as pharmaceutical and cosmetics manufacturing. Compounded from FAD approved ingrediients (CFR Title 21 Part 177.2600).	-20°F (-7°C) to +180°F (+82°C)
Silicone	L	Red Stripe	Good for dry, hot air without hydrocarbons and some high temperature chemical services. May also be used for fire protection dry systems.	-29°F (-34°C) to +350°F (+177°C)
Fluoro-elastomer (Viton)	O	Blue Stripe	Good for many oxidizing acids, petroleum oils, halogenated hydrocarbons, lubricants, hydraulic fluids, organic liquids and air with hydrocarbons to +300°F (+149°C).	-20°F (-7°C) to +300°F (+149°C)

Warranty:

We warrant all Argco Brand Grooved products to be free from defects in materials and workmanship under normal conditions of use and service. Our obligation under this warranty is limited to repairing at our option at our factory or designated facility any product which shall within 10 years after delivery to the original buyer be returned with transportation charges prepaid, and which our examination and inspection shall show to our satisfaction to have been defective.

This warranty is made expressly in lieu of any other warranties, express or implied, including any implied warranty of merchantability or fitness for a particular purpose. The buyer's sole and exclusive remedy shall be for the replacement or repair of defective products as provided herein. The buyer agrees that no other remedy (including but not limited to), incidental or consequential damages for lost profits, lost sales, injury to person or property or any other incidental or consequential loss shall be available to him/her.

Argco neither assumes nor authorizes any person to assume for it any other liability in connection with the sale of such products.

This warranty shall not apply to any product which has been the subject to misuse, negligence or accident, which has been repaired or altered in any manner outside of Argco's factory or designated facility or which has been used in a manner contrary to Argco's instructions, recommendations or generally accepted practices. Argco shall not be responsible for design errors due to inaccurate or incomplete information supplied by the buyer or his representatives.

BOLT TORQUE FOR GROOVED



ARGCO couplings and mechanical tees are supplied complete with factory bolts and nuts. The bolt and nut torque is primarily a function of the bolt and nut size. The following table shows guidelines for nut and bolt torque and can be used when setting the torque on power drivers

Bolt Size in	N-m Lbs - ft	Bolt Size in	N-m Lbs - ft
5/16	15 - 20	3/4	1100 - 135
M8	11 - 15	M20	74 - 100
3/8	25 - 30	7/8	170 - 275
M10	18 - 22	M22	125 - 200
1/2	50 - 68	1	275 - 400
M12	37 - 50	M24	200 - 300
5/8	80 - 120		
M16	60 - 90		

Do not exceed the design torque guidelines by more than 25%, as excessive torque could lead to joint failure. Always tighten nuts evenly and equally by alternating sides to prevent the gasket from being pinched and always check to make sure the coupling keys are fully engaged in the grooves.

FLEXIBLE COUPLINGS

The bolt pads on flexible couplings have been designed to meet metal to metal when properly installed. Bolt pad gaps

Table 1
Flexible Coupling Torque Guidelines

Bolt Size in	XGQT2 N-m/Lbs-ft	1212 N-m/Lbs-ft
1	60-70	---
	45-50	---
1-1/4	60-70	60-70
	45-50	45-50
1-1/2	60-70	60-70
	45-50	45-50
2	60-70	60-70
	45-50	45-50
2-1/2	60-70	90-100
	45-50	65-75
3	60-70	90-100
	45-50	65-75
4	90-100	90-100
	65-75	65-75
5	90-100	200-230
	65-75	145-170
6	90-100	200-230
	65-75	145-170
8	200-230(JIS216 270-300)	270-300
	145-170(JIS216 200-220)	200-220
10	270-300	270-300
	200-220	200-220
12	270-300	270-300
	200-220	200-220

regardless of their size, are not acceptable on flexible couplings. The listed values in the table 1 are guideline torque values listed by the coupling size. Please note these are only guidelines and that the actual torque value may be less than those listed to achieve a proper assembly. Actual torques for assembly of flexible couplings are normally as little as 15-20 N-m (11-15 Lbs-) for the bolt size of M10 (3/8") and 30-40 N-m (22 to 30 Lbs-) for the M12 (1/2") bolt size.

Do not attempt to add further torque after the bolt pads make metal to metal contact. If the bolt pads do not make full metal to metal contact, increase the torque to the listed guideline in table 1. Do not exceed the listed torque by more than 25%, as excessive torque could lead to joint failure. If bolt pad gaps still exist after bolts and nuts have been tightened to the guideline torque, then this would indicate a problem in the assembly, pipe and or groove dimensions.

ANGLE PAD RIGID COUPLINGS

The bolt pads on angle-pad rigid couplings and butt-joint rigid couplings have been designed to meet metal to metal when properly installed. In addition as the bolts are tightened the bolt pads will slide against one another creating a slight offset. This offset should be equal on each side and is your visual indication that the coupling has been installed properly for a rigid connection. Bolt pad gaps, regardless of their size, are not acceptable on angle-pad coupling. The listed values in the table 2 are guideline torque values listed by the coupling size. Please note these are only guidelines and that the actual torque value may be less than those listed to achieve a proper assembly.

Table 2
Torque Guidelines for Angle-pad Rigid Couplings

Size in	1512 N-m/Lbs-ft	GKS N-m/Lbs-ft	XGQT4 N-m/Lbs-ft
1	---	60-70	60-70
	---	45-50	45-50
1-1/4	60-70	60-70	60-70
	45-50	45-50	45-50
1-1/2	60-70	60-70	60-70
	45-50	45-50	45-50
2	60-70	60-70	60-70
	45-50	45-50	45-50
2-1/2	90-100	60-70	60-70
	65-75	45-50	45-50
3	90-100	60-70	90-100
	65-75	45-50	65-75
4	90-100	90-100	90-100
	65-75	65-75	65-75
5	200-230	90-100	90-100
	145-170	65-75	65-75
6	200-230	90-100	200-230
	145-170	65-75	145-170
8	270-300	200-230	200-230
	200-220	145-170	145-170
10	270-300	270-300	---
	200-220	200-220	---
12	270-300	270-300	---
	200-220	200-220	---

ROLL GROOVE SPECIFICATIONS



Standard Roll Groove for ANSI B36.10 and Other IPS Pipe

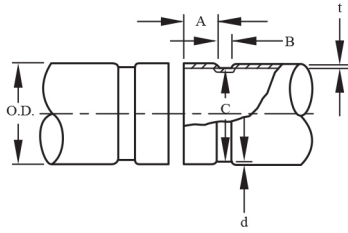

1 Nominal Size mm/in	2 Pipe O.D.		3 A ±0.76 ±0.030	4 B ±0.76 ±0.030	5 C +0.00 +0.000	6 Min. Wall t mm/in	7 Groove Depth d (ref.) mm/in	8 Max. Allowed Flare Dia. mm/in
	Basic mm/in	Tolerances						
20	26.7	+0.25 -0.25	15.88	7.14	23.83-0.38	1.65	1.42	29.2
0.75	1.050	+0.010 -0.010	0.625	0.281	0.938-0.015	0.065	0.056	1.15
25	33.4	+0.33 -0.33	15.88	7.14	30.23-0.38	1.65	1.60	36.3
1	1.315	+0.013 -0.013	0.625	0.281	1.190-0.015	0.065	0.063	1.43
32	42.2	+0.41 -0.41	15.88	7.14	38.99-0.38	1.65	1.60	45.0
1.25	1.660	+0.016 -0.016	0.625	0.281	1.535-0.015	0.065	0.063	1.77
40	48.3	+0.48 -0.48	15.88	7.14	45.09-0.38	1.65	1.60	51.1
1.5	1.900	+0.019 -0.019	0.625	0.281	1.775-0.015	0.065	0.063	2.01
50	60.3	+0.61 -0.61	15.88	8.74	57.15-0.38	1.65	1.60	63.0
2	2.375	+0.024 -0.024	0.625	0.344	2.250-0.015	0.065	0.063	2.48
65	73.0	+0.74 -0.74	15.88	8.74	69.09-0.46	2.11	1.98	75.7
2.5	2.875	+0.029 -0.029	0.625	0.344	2.720-0.018	0.083	0.078	2.98
80	88.9	+0.89 -0.79	15.88	8.74	84.94-0.46	2.11	1.98	91.4
3	3.500	+0.035 -0.031	0.625	0.344	3.344-0.018	0.083	0.078	3.60
90	101.6	+1.02 -0.79	15.88	8.74	97.38-0.51	2.11	2.11	104.1
3.5	4.000	+0.040 -0.031	0.625	0.344	38.34-0.020	0.083	0.083	4.10
100	114.3	+1.14 -0.79	15.88	8.74	110.08-0.51	2.11	2.11	116.8
4	4.500	+0.045 -0.031	0.625	0.344	4.334-0.020	0.083	0.083	4.60
125	141.3	+1.42 -0.79	15.88	8.74	137.03-0.56	2.77	2.11	143.8
5	5.563	+0.056 -0.031	0.625	0.344	5.395-0.022	0.109	0.083	5.66
150	168.3	+1.60 -0.79	15.88	8.74	163.96-0.56	2.77	2.16	170.9
6	6.625	+0.063 -0.031	0.625	0.344	6.455-0.022	0.109	0.085	6.73
200	219.1	+1.60 -0.79	19.05	11.91	214.40-0.64	2.77	2.34	223.5
8	8.625	+0.063 -0.031	0.750	0.469	8.441-0.025	0.109	0.092	8.80
250	273.0	+1.60 -0.79	19.05	11.91	268.27-0.69	3.40	2.39	277.4
10	10.750	+0.063 -0.031	0.750	0.469	10.562-0.027	0.134	0.094	10.92
300	323.9	+1.60 -0.79	19.05	11.91	318.29-0.76	3.96	2.77	328.2
12	12.750	+0.063 -0.031	0.750	0.469	12.531-0.030	0.156	0.109	12.92

Pipe OD (Column 2): Maximum allowable tolerances from square cut ends is 0.03" for size up to 3 1/2"; 0.045" for 4" thru 6"; and 0.060" for size 8" and above.

Gasket Sealing Surface (Column 3): The gasket sealing surface shall be free from deep scores, marks, or ridges that could prevent a positive seal.

Groove Width (Column 4): Groove width is to be measured between vertical flanks of the groove side walls.

Groove Diameter (Column 5): The "C" diameters are average values. The groove must be of uniform depth around the entire pipe circumference.

Minimum Wall Thickness (Column 6): The "t" is the minimum allowable wall thickness that may be roll-grooved.

Groove Depth (Column 7): The "d" is for reference use only. The groove dimension shall be determined by the groove diameter "C".

Flare Diameter (Column 8): The pipe end that may flare when the groove is rolled shall be within this limit when measured at the extreme end of the pipe.



ALLIED RUBBER &
GASKET COMPANY
800.854.1015
sales@argco.com
www.argco.com